



*An Online CPD Course
brought to you by
CEDengineering.ca*

Fish Passage and Screening Design

Course No: C07-021

Credit: 7 PDH

Jeelan Moghraby, Ph.D., MBA.

CEDE CANADA
engineering.ca
CPD FOR THE PROFESSIONAL

Continuing Education and Development, Inc.

P: (877) 322-5800

info@cedengineering.ca

www.cedengineering.ca

This course was adapted from the U.S. Department of Agriculture, National Resources Conservation Service, Technical Supplement 14N, Fish Passage and Screening Design, Part 654 of the National Engineering Handbook, which is in the public domain.

TABLE OF CONTENTS

Introduction 1

 1. Passage barrier and screening overview 1

 2. Federal and state authority and regulations 2

Biological design considerations 3

 1. Migration type 4

 2. Migration schedule 5

 3. Physical characteristics and capabilities 6

 4. Warm-water and cold-water species 6

 5. Body type and size 7

 6. Swimming and leaping capabilities 8

 7. Behavioral responses 11

 8. Life cycle histories and physical characteristics information 12

Incorporating biology into design 12

 1. Velocity 12

 2. Depth 13

 3. Jump height and pool length 14

Behavioral attractors 14

Fish passage and screening design 15

 1. Site assessment 16

 2. Hydrologic analysis overview 17

 3. Hydrologic analysis for gaged streams 18

 4. Hydrologic analysis for ungaged streams 19

 5. Hydraulic analyses overview 19

 6. Hydraulic models 20

Concrete fishways and ladders 21

 1. General overview 21

 2. Weirs, orifices and gates (flow controls) 25

 3. Concrete ladder pools 28

 4. Entrance and attractors 32

 5. Exit 33

 6. Rock fishways 34

Roughened channel fishways 40

 1. Engineered channel 40

 2. Denil 41

 3. Alaska Steeppass 43

 4. Culvert modification and design 44

Tide gates and floodgates 58

 1. Fishway operation and maintenance 61

| | |
|---|----|
| 2. Fish screen design..... | 62 |
| 3. Screen design approach | 69 |
| Bypass design | 73 |
| 1. Maintenance and operation..... | 74 |
| 2. Example problem: Preliminary design for fish passage | 74 |

LIST OF FIGURES

| | |
|---|----|
| Figure 1. Fish body types | 8 |
| Figure 2. Fish passage design process | 16 |
| Figure 3. 2-year, 2-day duration design discharge | 18 |
| Figure 4. Plan view of a generalized concrete ladder dish passage facility | 21 |
| Figure 5. Cross section and profile views of a pool and weir/orifice fishway | 24 |
| Figure 6. Plan and end views of a vertical slot fishway | 25 |
| Figure 7. Weir schematic..... | 26 |
| Figure 8. Orifice (gate) schematic | 27 |
| Figure 9. Plunging and streaming flow | 28 |
| Figure 10. D number parameters for evaluating hydraulic jump geometry of a vertical drop spillway..... | 29 |
| Figure 11. Plan view of a generalized roughened rock channel/rock ladder fishway | 34 |
| Figure 12. Boulder weir (plan view) | 35 |
| Figure 13. Boulder weir cross section | 36 |
| Figure 14. Boulder step-pool profile | 37 |
| Figure 15. (a) North Dam on the Red River of the North (ND) before construction; (b) after construction of an engineered channel fishway..... | 41 |
| Figure 16. (a) Site photo; (b) schematic of a common Denil fishway | 42 |
| Figure 17. (a) Site photo; (b) schematic of an Alaska Steeppass fishway | 43 |
| Figure 18. A significantly perched culvert | 45 |
| Figure 19. Series of channel spanning weirs used to step up water surface..... | 45 |
| Figure 20. Common baffle styles for round and box culverts | 46 |
| Figure 21. Round, corrugated metal culvert retrofitted with..... | 47 |
| Figure 22. General flowchart of culvert design process..... | 48 |
| Figure 23. No-slope option culvert schematic..... | 49 |
| Figure 24. Undersized perched culvert (left) replaced with | 53 |
| Figure 25. Low (<4%) and high (>4%) bed slope stream simulation culvert design schematics | 55 |
| Figure 26. Hydraulic design option culvert schematic | 57 |
| Figure 27. Improved fish passage..... | 59 |
| Figure 28. Self-regulating tide gate | 61 |
| Figure 29. Potential fish screen configuration and locations | 62 |

Figure 30. Vertical fixed plate screen..... 65
Figure 31. Vertical traveling screen 66
Figure 32. Rotary drum screen 67
Figure 33. Pump intake screens..... 68
Figure 34. Infiltration gallery 69
Figure 35. Fish screen wire and mesh configurations 70
Figure 36. Sweeping and approach velocities 72

LIST OF TABLES

Table 1. Examples of diadromous life histories and species..... 4
Table 2. Examples of potamodromous life histories and species..... 5
Table 3. Example of maximum swimming speeds and maximum jumping heights..... 9
Table 4. Relative swimming speeds of average-sized adult fish..... 10
Table 5. Relative swimming speeds of young fish..... 11
Table 6. Jump height coefficient 30
Table 7. Incipient motion thresholds for rock sizes 39
Table 8. Maximum lengths for no-slope culverts..... 51
Table 9. Examples of screen materials for fry-sized salmonids <60mm (minimum 27% open area) 71
Table 10. Steelhead swimming design criteria..... 76

Introduction

Fish passage and screen facility design is often a significant component in stream restoration and water resource management. A wide variety of issues often arise regarding passage and screening design, depending on the project region and species of interest. This technical supplement provides an overview of fish passage and screening design approaches that incorporate biological considerations into the hydraulics of commonly used structures; guidance on site assessment and operations and maintenance (O&M) of fishways and screens; an overview of assessment and design approaches for fishways and screens, ladders, culverts, tide gates, and floodgates; and finally, an example design is presented.

1. Passage barrier and screening overview

Fish migration is a natural, usually seasonal life cycle function, as fish move in large numbers from one habitat type to another to spawn, feed, grow, or seek refuge from predators. Federal and state regulations often require mitigation for passage barriers and water intakes or diversions that entrain fish. As a result, the timing, duration, and frequency of fish migrations must be accounted for when planning and implementing water resource projects within a watershed.

Passage barriers are primarily a problem for fish trying to move upstream in an estuary, river, or stream. Both natural and manmade barriers occur within river and stream systems. Natural physical barriers include features such as waterfalls, cascades, and large rapids. Common manmade physical barriers include dams, diversions, culverts, weirs, and grade control and sill structures. Chemical and biological barriers also exist in many rivers across the United States, including water quality (temperature) and predation from non-native species. Virtually all manmade barriers impede fish passage, limit natural migration patterns, regulate population dynamics, and fragment diverse habitats.

Physical fish barriers are classified by water velocity, water depth, and barrier height. The magnitude of a fish passage impediment can generally be classified as:

- partial—impassable to some species or certain age classes all or most of the time
- temporary—impassable during some times to all or most species and/or age classes (during low-flow conditions)
- complete—impassable to all fish at all times

Some situations present difficult conditions under which passage for all fish species and size classes cannot be provided 100 percent of the time. However, typical design modifications for fish passage barrier mitigation include the following:

- culvert removal, modification, or replacement

- channel modification
- structural fish passage features (concrete or metal ladders and chutes)
- natural-type fish passage design (rock riffles, rock aprons, step-pool rock ladders)
- dam or barrier removal or modification

In addition to fish barriers, fish entrainment into water diversions or pump intake structures also affects natural migration patterns—primarily for downstream movement, but sometimes for upstream movement. Typically, fish screens are used to prevent adult and juvenile fish entrainment or attraction into manmade diversion structures or other features (power or sewage treatment plant outfalls). Typical types of surface and subsurface diversion structures requiring fish screens include municipal and irrigation water intakes, irrigation diversions, and pump stations. Protecting fish from entrainment at these structures may be achieved through the use of the following features:

- physical barriers and screens
- behavioral guidance to direct swimming direction
- capture and release systems

This technical supplement provides general design guidance for three types of fish passage features: concrete fishways, step-pool rock ladders, and roughened channels (engineered channel, Denil, and Alaskan Steep pass). Additionally, approaches are described for modifying or replacing existing culverts to improve or provide fish passage. Considerations for tide gates and floodgates are also presented. Finally, screen design guidance addressing active and passive screening approaches for gravity and pumped diversions is presented.

2. Federal and state authority and regulations

Federal and state regulations require fish passage and protection from fish entrainment under several authorities that require water resource project developers to mitigate for impacts to fisheries resources. For example, under the Endangered Species Act (ESA) it is illegal to knowingly take a fish that is listed as threatened or endangered. The ESA and other Federal and state laws may require that a design provides passage upstream of barriers and prevents entrainment into diversion structures or pump intakes. The following sections provide an overview of passage and screening design criteria often promulgated in Federal and state regulations. Designers should contact local authorities and experts to determine if species, season, or region-specific passage and screening criteria are emphasized in the project area.

Several authorities and regulations require the implementation of fish passage and screening projects. In many parts of the United States, fish passage and screening projects are undertaken to protect ESA-listed species and state species of concern and enhance their

habitat. The National Oceanic and Atmospheric Administration National Marine Fisheries Service (NOAA Fisheries Service), U.S. Fish and Wildlife Service (USFWS), and state game and fish agencies are excellent contacts for legal requirements and technical criteria. Generally, projects that are authorized, funded, or carried out by the U.S. Department of Agriculture (USDA) Natural Resources Conservation Service (NRCS) are subject to ESA Section 7 consultation unless they clearly have no effect on listed resources. When the project is likely to affect listed fish (even if the effects are completely beneficial), the project designer must comply with technical criteria from NOAA Fisheries Service or USFWS when designing fishways or screening facilities to expedite the consultation process and increase the likelihood of project success. However, in all projects, NRCS personnel should strive to design fishways and screens that protect all aquatic resources and provide private landowners with workable solutions. More information on permits, process, and regulatory requirements is provided in NEH654.13.

Biological design considerations

The design of a fish passage or screening project begins with identifying the current or historical distribution and migratory patterns of fish species in the project area. Target species can be those listed as threatened or endangered under the ESA and/or state species of concern, other native species, or aggressive nonnative species tagged for potential exclusion (species to be isolated at a sorting facility in a fish passage). The project design should be based on the physical limitations of the weakest species requiring passage and accommodating the smallest size within that species, wherever feasible, based on stream conditions (Washington Department of Fish and Wildlife (WDFW) 2000a). These physical limitations are usually based on biological data and characteristics and are then used to develop the design criteria for fish passage and screening structures (Bates 1992).

The following planning sequence and biological characteristics are often evaluated when developing design criteria for a fish passage or screen project:

- Step 1* Identify the target species for fish passage or screening.
- Step 2* Determine the migratory timing and life history stage at migration.
- Step 3* Determine the physical limitations on fish passage (swimming speed, jumping ability).
- Step 4* Identify the environmental attractors and stressors (flow volumes, flow velocity, water temperature, seasonal timing).
- Step 5* Identify any relevant behavioral characteristics of the target species that could affect fish passage (water temperature preferences and avoidances).

Many fish species must migrate to satisfy their habitat requirements for foraging, resting, rearing, and spawning. Additionally, many resident freshwater species commonly move several miles within freshwater systems on a daily or monthly basis for feeding or sheltering purposes. Migrating or moving fish are vulnerable to injury and mortality if normal movement patterns are blocked or impeded by constructed barriers. They are also more susceptible to injury as they try to negotiate manmade barriers. If fish passage is impeded during spawning migrations, impacts on population can be severe and include decreased egg size and abundance, decreased red excavation success, and outright mortality (Rainey 1991).

1. Migration type

Migratory life history strategies vary widely and include bidirectional migrations between marine and freshwater environments (diadromy), or solely within freshwater environments (potamodromy). Most major migrations occur for reproduction (spawning) purposes (anadromous and catadromous fishes), although large-scale movements also occur seasonally as fish exploit food resources along inland rivers, estuaries, and coastlines. Fish migration categories and strategies are briefly described in tables 1 and 2.

| Category | Description/life history strategy | Species |
|--------------|---|---|
| Anadromous | Species that incubate and hatch in freshwater, migrate to saltwater as juveniles to grow, and return to freshwater as adults to spawn | Alewife; striped bass; Atlantic, coho, pink, chum, sockeye, and Chinook salmon; steelhead, cutthroat, and bull trout; dolly varden; sturgeon; American shad; perch; Atlantic herring; sea and Pacific lamprey |
| Catadromous | Species that hatch in saltwater, migrate to freshwater as juveniles to grow, and return to saltwater to spawn | American eel |
| Amphidromous | Species that move between fresh and saltwater during some part of life cycle, but not for breeding | Sawfish, gobies, other tropical fishes |

Table 1. Examples of diadromous life histories and species

| Category | Description/life history strategy | Species |
|-----------|---|--|
| Adfluvial | Species that hatch in rivers or streams, migrate to lakes as juveniles to grow and return to rivers or streams to spawn | Bull trout, cutthroat trout, kokanee, smelt, suckers |
| Fluvial | Species that live in the flowing waters of rivers or streams, but migrate between rivers and tributaries for breeding, feeding, or sheltering | Bull trout, cutthroat trout, brown trout, rainbow trout, Arctic grayling, sturgeon, paddlefish, pike |

Table 2. Examples of potamodromous life histories and species

2. Migration schedule

Migration timing is tied to species life stage (spawning), time of day (foraging or predatory migrations), changes in water temperature, increases in flow rates, or changes in flow direction (tides). In addition, migrations can occur hourly, daily, monthly, and seasonally in fish populations across the United States and Caribbean area. Providing uninterrupted passage or continuous operational screening is often very difficult, and it is likely that any given project will have short periods of inoperation or down time. However, project designers should develop fish passage and screening approaches that provide the best level of protection for sensitive life histories and important migratory periods and that have the greatest effect on population health and sustainability.

Since migration timing and frequency of movement vary among species and watersheds, knowledge of the specific behavior of the target species is necessary for development of fish passage and screening criteria. Different species or age classes may migrate at different times of the year; multiple hydrologic analyses may be needed to determine the controlling hydraulic requirements at any particular site. Movements may occur both upstream and downstream.

Generally, anadromous adult salmon and steelhead spawning migrations occur during a distinct season (fall, winter, spring, or summer). Juvenile salmon rearing in freshwater migrate first in the spring as fry and later in the summer and early fall as fingerlings or parr, searching out different habitats as they grow (WDFW 1999). The largest movement of anadromous salmonids occurs in the spring, as juveniles transition (smolt) from their freshwater rearing areas into the productive ocean environment where they will grow to adulthood. Anadromous fish on the Atlantic coast primarily make spawning runs in the spring, and adults reproduce in estuarine or freshwater stream habitats. Conversely, catadromous American eels of the eastern coast of the United States live in freshwater streams and lakes for up to 5 years before they

journey to the Sargasso Sea of the Atlantic Ocean near Bermuda to spawn. Juvenile eels spend about a year in the ocean before returning to freshwater where they grow to adulthood.

Freshwater migrations occur for spawning and foraging purposes. A study of warm-water fish in Arkansas shows bidirectional movement in streams and is not influenced by season (Warren and Pardew 1998). Redhorses, carpsuckers, catfish, muskellunge, walleye, and northern pike migrate along the Fox River in Illinois virtually year-round for foraging purposes, but only between May and July for spawning (Illinois Department of Natural Resources 2000). Young (1994) found that brown trout in south-central Wyoming moved more than 60 miles during the spawning season between mainstem rivers and adjoining tributaries. Studies by Young (1996) and Colyer et al. (2005) suggest that salmonids often undertake lengthy daily and seasonal migrations to exploit feeding areas, seek refuge or resting cover, and colonize new habitats. In addition to longitudinal (main channel) migrations, movements may occur laterally between the main channel and side channels, emergent wetlands, or backwaters. For example, some species such as northern pike spawn in side channels, oxbows, and flood plain ponds adjacent to large river systems.

3. Physical characteristics and capabilities

In any given stream system, juveniles and/or adults may be present during different times of the year and most likely have different swimming abilities and passage requirements. Consequently, design of fish passages and screens should incorporate available information on the specific physical capabilities of target species. These physical characteristics and capabilities vary depending on the species and life stages present, but will likely include fish body type and size, swimming ability, impact resistance, and leaping ability.

Generally, physical characteristics and swimming capabilities become the biological basis for engineering design criteria in a fish passage or screening project. For example, fish passage features designed for salmonids consider the swimming capabilities of migrating adult fish headed for spawning areas. Swim speed (burst and sustained) and distance, minimum swim depths, maximum jump/drop height, and pool approach depths are critical in providing upstream navigation for spawners. For fish screens, downstream migration of juvenile salmonids focuses more on body size, sweeping velocities, orientation to flow, and cross-sectional streamflow patterns to prevent unwanted entrainment and impingement on the structure.

4. Warm-water and cold-water species

The physical form and capabilities of a given species are products of evolutionary and behavioral adaptations to its physical and biological environment. The most basic distinction between fish species is their adaptation to water temperatures, and swimming performance can

be directly affected by thermal conditions. Most fish are ectotherms, meaning that their body temperature is mainly regulated by their external environment. Consequently, water temperature is one of the most important physical factors affecting the behavior, physiology, and distribution of fish (Great Lakes Information Network 2004). Fish are often classified as either cold-water or warm-water species. Cold-water fish such as trout and salmon generally require temperatures below 70 degrees Fahrenheit, while warm-water species like bass and catfish thrive in temperatures primarily above 70 degrees Fahrenheit.

5. Body type and size

Body shapes and size of fish and aquatic organisms at maturity are often adapted to the flow regimes and general physical attributes of their respective habitats (Food and Agriculture Organization of the United Nations 2002). For example, fish in fast-flowing reaches of higher gradient streams often have torpedo-shaped bodies that offer lower flow resistance (steelhead, rainbow trout). Conversely, high-backed fish (carp and razorback suckers) colonize rivers with more gentle currents or deeper average depths (fig. 1 (Schua and Schua 1970)). Body size at a given age is especially important in screen design. Some fish species are very small shortly after hatching and are more susceptible to entrainment into surface diversions or pumping stations. Likewise, the adults of many species of fish never grow to more than 4 to 6 inches and are similarly in danger of being entrained into pumps or canals. Small-bodied or weak-swimming fish are susceptible to being impinged on fish screens where they will eventually die or fall victim to predators.

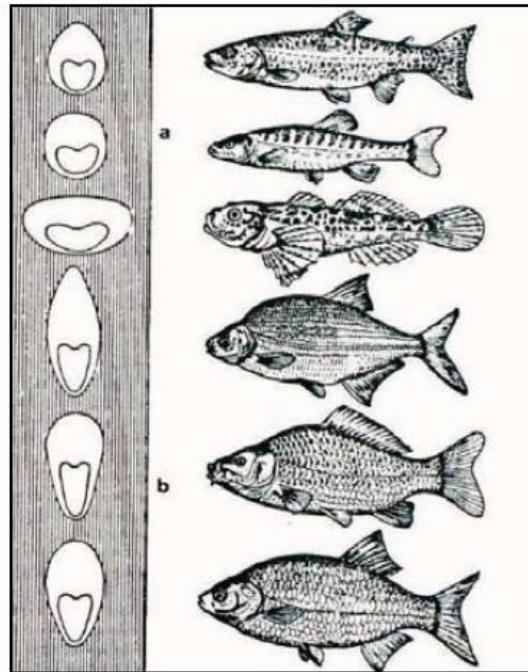

Figure 1. Fish body types

6. Swimming and leaping capabilities

The swimming speeds and jumping capabilities of a fish are adaptations to stream morphology, flow characteristics, and migratory life history. The swimming and jumping characteristics of a fish are defined as:

Burst (darting) speed — highest swimming speeds; endurance less than 20 seconds; ends in extreme fatigue

Sustained speed — low swimming speeds; maintained for extended time periods with little to no fatigue

Cruising speed — intermediate swimming speeds; endurance 20 seconds to 200 minutes; ends in fatigue

Jumping height — a function of swimming speed and water depth, jumping height is the maximum height obtained by a specific species and age of fish. Older and larger fish have greater maximum jumping heights, although some species have no jumping abilities at any age.

The swimming speeds and maximum jumping heights have been researched in controlled settings and documented for many fish species, with particular emphasis on salmonids. Table 3 lists the known maximum swimming speeds and maximum jumping heights for adult salmonid species (Bjornn and Reiser 1991).

| Salmonid species | Sustained speed | | Cruising speed | | Burst speed | | Maximum jump height | |
|------------------|-----------------|------|----------------|------|-------------|------|---------------------|-----|
| | ft/s | m/s | ft/s | m/s | ft/s | m/s | ft | m |
| Steelhead | 4.6 | 1.40 | 13.7 | 4.18 | 26.5 | 8.08 | 11.2 | 3.4 |
| Chinook | 3.4 | 1.04 | 10.8 | 3.29 | 22.4 | 6.83 | 7.8 | 2.4 |
| Coho | 3.4 | 1.04 | 10.6 | 3.23 | 21.5 | 6.55 | 7.2 | 2.2 |
| Cutthroat | 2.0 | 0.61 | 6.4 | 1.95 | 13.5 | 4.11 | 2.8 | 0.9 |
| Chum | 1.6 | 0.49 | 5.2 | 1.58 | 10.6 | 3.23 | 1.7 | 0.5 |
| Sockeye | 3.2 | 0.98 | 10.2 | 3.11 | 20.6 | 6.28 | 6.9 | 2.1 |

Table 3. Example of maximum swimming speeds and maximum jumping heights for selected adult salmonids

Salmonids are strong swimmers and leapers (Tillinger and Stein 1996) (table 4 ((modified from Bell 1990)) especially in comparison to warm-water species and other migratory species. However, although salmon and steelhead are famous for their swimming and leaping abilities, their physical prowess steadily weakens as they swim further and further into freshwater habitats. Many fish species cannot or will not jump over obstructions; shad and herring can be blocked by a structure only 1 foot high (USFWS 2004). Likewise, although chum and pink salmon are powerful swimmers, their leaping abilities are somewhat limited, and few individuals will attempt to negotiate vertical leaps much greater than 1 foot (Orsborn 1985). All of these factors should be considered when designing fishways, road crossings, or roughened channels.

Fish size and stage of development also affect swimming capabilities. Juvenile and smaller fish do not swim as strongly as healthy adults of the same species (table 5 (modified from Bell 1990)), so slower velocities should be considered in the design of fish passage and screening projects (Tillinger and Stein 1996). Projects in settings with a variety of fish species of differing body sizes and swimming capabilities can pose especially challenging design requirements. However, if the fishway or screen passes or protects the smallest or weakest swimming fish, it is likely that other fish seeking passage at the same time or when streamflow is higher will find adequate passage conditions or be protected from entrainment into diversions or pumps.

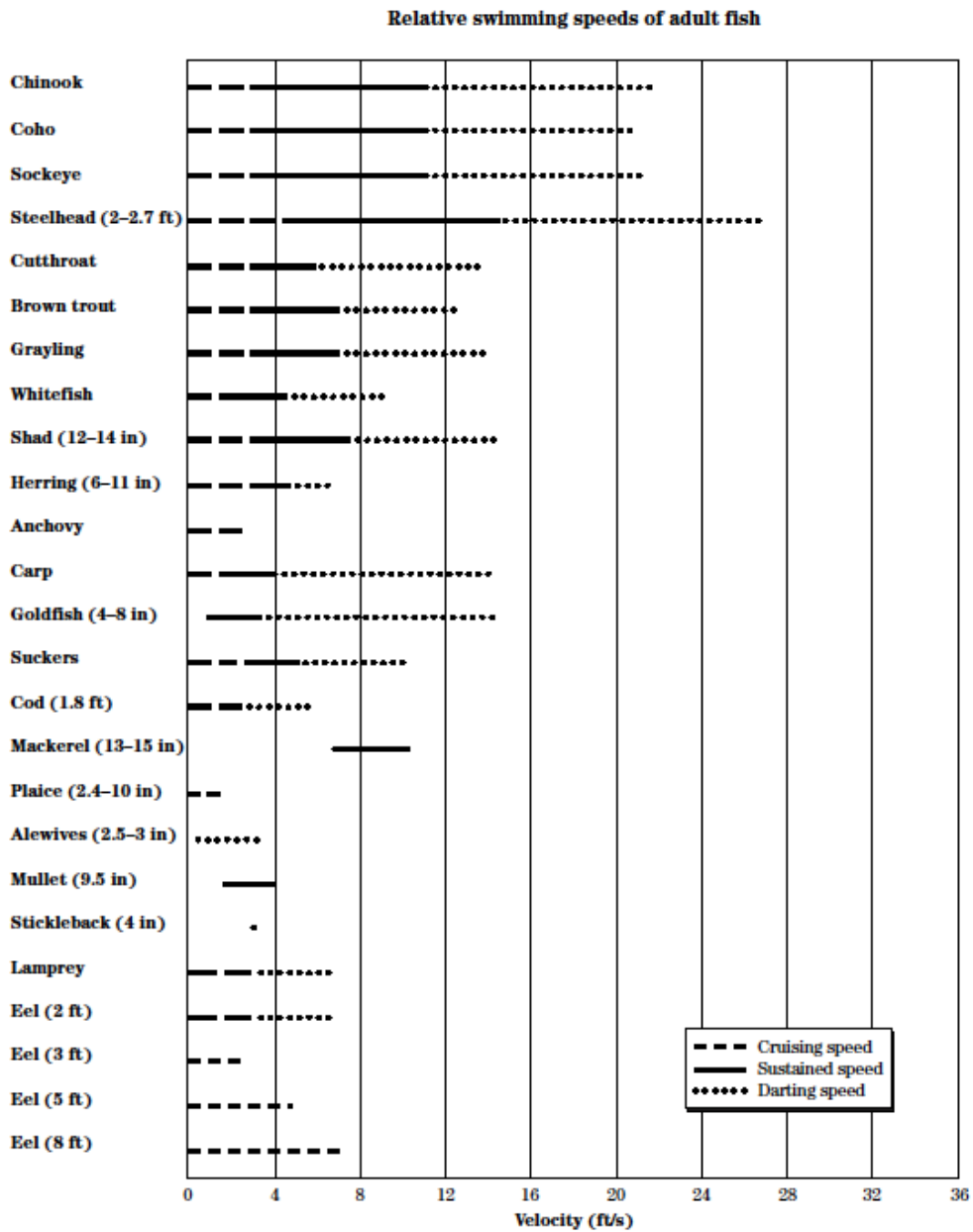

Table 4. Relative swimming speeds of average-sized adult fish

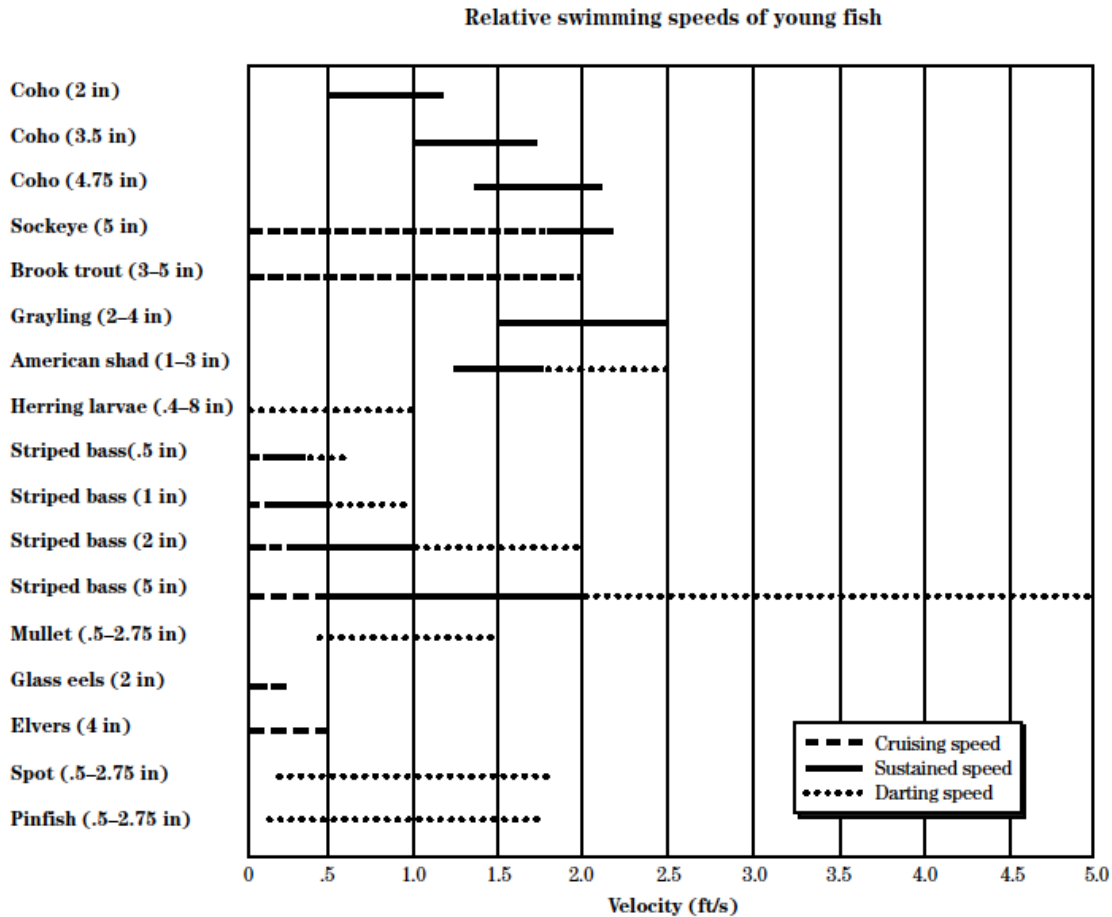

Table 5. Relative swimming speeds of young fish

7. Behavioral responses

Understanding the behavioral response of a species to stimuli enables the development of fish attractors and detractors for fish passage and screening projects. Attractors and detractors may take the form of shade, light, fishway water velocity, relative volume of fishway attraction flow to streamflow, temperature, sound, and shoreline or overhead movements. Fishway composition can be a very important factor determining success or failure. For example, some fish (shad) are hesitant to swim through a submerged orifice, instead preferring flow that is directed through a vertical slot or over a weir. Excessive turbulence at a fishway entrance may confuse or restrict target species, and the orientation of a fish ladder’s entrance to the adjacent stream channel is of the utmost importance. Many fish move up a river system by capitalizing on lower velocities along the bankline boundary layer. Conversely, juvenile emigrants are

usually found moving downstream in the fastest flowing portion of the channel, within 1 foot of the surface.

Ambient environmental conditions also greatly affect the migratory habits of fish. For many species, spawning migrations may be triggered by changes in water temperature. For example, Lower Columbia River white sturgeon spawn when water temperatures are between 48 degrees and 63 degrees Fahrenheit (Wydoski and Whitney 2003) and may be delayed or prevented when water temperatures are unsuitable (Fresh et al. 1999). Light can be used as an artificial guidance stimulus, repelling fish at higher intensities and attracting them at lower intensities (Bell 1990).

8. Life cycle histories and physical characteristics information

Further information on various aspects of life cycle history and physical characteristics for a variety of fish may be found at the following Web sites:

<http://www.nwrc.usgs.gov/publications/specindex.htm>

<http://www.fishbase.org>

Incorporating biology into design

Much is known about the physical capabilities and behavioral tendencies of many fish species. The design of fishways and screens should incorporate these physical characteristics and capabilities of targeted species. Swimming and leaping information for many fish species is not available. Designers should use recorded data from similar species with comparable swimming and behavioral characteristics.

Fish passage and screening facilities should not impose artificial conditions that exceed the natural locomotive abilities of fish or adversely affect their behavioral response to a given stimulus. The following section provides a few useful rules of thumb regarding biological requirements and capabilities, hydraulics, and fish passage and screen design. Additional qualitative and quantitative criteria are described later in this technical supplement for fishways and screens.

1. Velocity

Velocities within a fish passage structure should be less than the sustained swimming capability for each species in long uniform sections and less than burst swimming ability over short distances (Katopodis 1991). Fish that are forced to swim through a structure with bursts or sustained cruising speeds will suffer stress from fatigue. If adult or juvenile migratory fish are unduly fatigued by a fishway, their ability to survive and complete life history requirements

may be significantly diminished. Resting alcoves or cover must be provided if velocities within a fish passage structure exceed the swimming capabilities of the target species for long distances. Velocity breaks and shadows using boulders or large wood can be used to provide resting areas in roughened channels or fishways that are designed to mimic natural stream conditions. Species' velocity criteria would then be applied to flow areas between constructed resting areas.

For adult salmonid passage through a culvert, NOAA Fisheries Service (2000) recommends average calculated velocities of 6.0 feet per second for distances of less than 60 feet, 4.0 feet per second for distances between 100 and 200 feet, and 2.0 feet per second for distances greater than 300 feet. Recent studies found that warm-water fish passage through culverts less than 30 feet in length was reduced substantially at velocities over 1.3 feet per second (Warren and Pardew 1998). Conversely, salmonids are expected to sustain this velocity for more than 300 feet. Knowledge of the swimming abilities of target species is a vital element of the design process.

Fish screen designs must account for approach velocities in the forebay of the structure and sweep velocities along the face of the screen. Approach velocity is velocity perpendicular to the screen that may trap or impinge a fish against a screen. Physical contact with a screen face causes various injuries, and studies of fish biomechanics have been used to set hydraulic criteria for approach velocities (Pearce and Lee 1991). Sweep velocity is the velocity parallel to the face of the screen that sweeps fish along its face and into a bypass that will take them back to a river or other water body. For juvenile salmonids, NOAA Fisheries Service (2000) and WDFW (2000a) recommend an approach velocity of 0.4 feet per second in rivers and streams, and 0.33 feet per second in lakes and reservoirs. Sweeping velocity should always be greater than approach velocity, regardless of screen location in a river, lake, or other body of water.

2. Depth

Minimum low-flow depths within fishways should be maintained to accommodate fish size, swimming abilities, and behavioral responses. For pool style fishways or channel-spanning structures, WDFW (2000a) recommends a maximum head differential of 12 inches for most adult salmonids, 6 inches for juvenile salmonids, and 3 inches for grayling. These depths are difficult to attain in many culvert crossings on small headwater streams at baseflow, so culvert size, shape, composition, and installation techniques become important factors that regulate passage.

Minimum operating depth at screening facilities depends on the type of screen and site hydraulics. However, a good rule of thumb to protect juvenile or small bodied fish is to provide a minimum of 2.5 square feet of submerged screen for every cubic foot per second of flow diverted through it.

3. Jump height and pool length

The jumping heights of target species must be identified when designing a fish passage structure using stepped pools or weirs. These typically include a maximum vertical height, and the jump pool length and depth needed to allow the fish to generate enough speed to clear the barrier. In addition, pool spacing and configuration must satisfy resting requirements of all target species. The WDFW (2003) has developed the following recommendations for salmonid passage structures based on the species' swimming and leaping capabilities:

- *Entrance jump* (maximum vertical height) into a fish passage project should be no greater than 1 foot for salmon and steelhead adults and 6 inches for adult trout, kokanee salmon, and steelhead juveniles. These jump heights should also be considered as maxima when a series of jumps and pools are required.
- *Jump pool* (where entrance jumps are planned) must be at least 1.5 times the jump height or at least 2 feet deep to account for resting requirements of salmonid species.

Traditionally, fish passage projects have been designed based primarily on the capabilities of jumping species (salmonids) and only recently have non-jumping fish been considered (Peake et al. 1997). Chute ladders or roughened channels (rapid/pools or riffle/pools) without discrete drops can provide adequate fish passage for non-jumping target species.

Behavioral attractors

Many fish passage structures use high velocity attraction flow at or near their entrances. This practice is based on behaviors observed in salmonids. Migratory salmon and steelhead tend to assume upstream migration paths by “cueing-in” on higher velocity currents. A fishway entrance can be designed as a constriction to increase velocities compared to surrounding flow conditions, guiding fish into the structure based on their natural behaviors in finding upstream migration paths. When gravity flow through a passage structure decreases, auxiliary pumps may be required to supply high velocity attraction flow near fishway entrances. Alternative behavioral attractors, including entrance size, light, and acoustics are being explored in many areas of the Pacific Northwest. For example, recent studies show that salmonid species will select smaller, well-lit entrances over larger, darker ones (Oregon Department of Fish and Wildlife 2004).

Predation

Predation is a common problem at many fish passage and fish screen facilities. Avian predation most often occurs along screening structures, where birds can either land or wade near the fish screen, or dive underwater and prey on disoriented fish at the bypass pipe exit. Birds are also known to prey on groups of fish stacked up at the entrance to a fishway. Piscine

or mammalian (seals and river otters) predation occurs wherever fish are in pools near the entrance to a fishway, along the face of screens, or bypass outlets downstream of a fish screen. Fish behavioral characteristics must be incorporated into screen and fish passage designs so that pooling and holding areas for predators are not adjacent to critical areas such as fishway entrances or bypass outlets. For example, fishway entrances or bypass pipes can be located in areas where site morphology and hydraulics discourage target species to rest due to higher velocities, inadequate cover, or unsuitable depth. Avian predation can be reduced by providing overhead cover or vegetation above the entrance to a fishway or outlet from a fish screen. Designers should take great care to minimize and mitigate avian, piscine (predatory fish), and mammalian predation in any sector of a fish screen or passage project where the target species is likely to congregate for any period of time. Care should also be taken to avoid excessive fatigue or disorientation of target species as they transit a passage or screen project because physical impairment can lead to higher predation rates.

Several resources are available to designers regarding fish passage and screen history, design, and research. Examples of fish passage projects and design criteria can be found at the following websites:

*<http://wdfw.wa.gov/hab/engineer/habeng.htm>
<http://www.fws.gov/fisheries/fwma/fishpassage/>
<http://www.nwfsc.noaa.gov/research/divisions/fed/fishpassage.cfm>
<http://swr.nmfs.noaa.gov/hcd/expert.htm>*

Examples of fish screen projects and design criteria can be found at the following websites:

*<http://wdfw.wa.gov/hab/engineer/habeng.htm#dwnstrm>
<http://swr.nmfs.noaa.gov/hcd/fishscrn.htm>
<http://swr.nmfs.noaa.gov/hcd/pumpcrit.pdf>*

Fish passage and screening design

As described in previous sections, the fish passage and screening design process often begins by collecting all available information for the species of interest pertaining to migration patterns, life history requirements, and swimming and leaping capabilities. An assessment of physical conditions and site suitability usually occurs concurrent with an evaluation of relevant biological factors for the target species. Fish passage design typically includes a site assessment including site survey, geologic and geomorphic characterization, hydrologic and hydraulic analyses, and structural design (fig. 2).

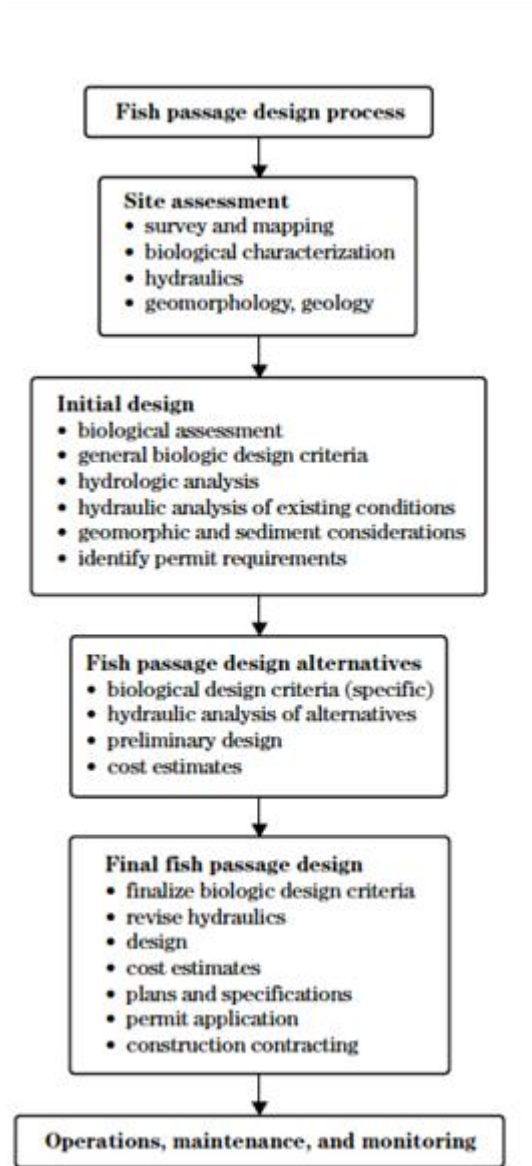

Figure 2. Fish passage design process

1. Site assessment

Site assessments are addressed in detail in NEH654.03. This section focuses on site assessments that are more specific to fish passage issues. The site assessment should include topographic and hydrographic surveys of the passage barrier and stream channel upstream and downstream of the barrier. Whenever possible, collect historic photos of the site, and interview nearby residents for their perspective on the area. Accurate contour and infrastructure (dams,

diversions) as-builts are essential for developing plans. Geomorphic assessment is necessary to characterize stream behavior and substrate conditions. In addition, depending on site conditions and proposed structures, geologic and geotechnical consultation may be necessary to characterize the soils, foundation, and river alluvium composition. Fish habitat characterization should also be performed to evaluate migration patterns, holding pool areas, and environmental conditions that will affect fish migration and use of the fish passage feature. The information developed in the site assessment is the foundation for developing topographic, geomorphic, edaphic, and biological criteria in final engineering designs.

2. Hydrologic analysis overview

The first step in the engineering design is the hydrologic analysis. Typically, designs require defining the range of high and low discharges the fish passage facility will operate within. Hydrologic analysis must consider the period of interest when migration occurs and when statistical analyses for streams with gage data typically include flood frequency and flow-duration investigations. Hydrologic information for ungaged streams may be based on regional regression equations, correlation analyses to similar, adjacent gaged streams, or runoff modeling. However, synthesizing streamflow data should only be undertaken in smaller watersheds of about 50 square miles or less.

Hydrologic analyses are used to describe streamflow timing, magnitude, frequency, and duration during the migration period of interest. Ultimately, this information will identify the operating conditions under which the fish passage or screening facility will function.

Regional guidelines from local fish and wildlife agencies provide suggestions regarding fish passage and typically identify design discharge analysis methods. For instance, NOAA Fisheries Service (2000) recommends that for streams where streamflow data are available, the high fish passage design flow for adult salmonids should be the 1 percent annual exceedance flow (This is not the 100-year storm.). For adult passage at low flows, NOAA Fisheries Service recommends using the 50 percent annual exceedance flow or 3 cubic feet per second (whichever is greater), and for juveniles, the 95 percent annual exceedance flow or 1 cubic foot per second (whichever is greater). Similarly, a design flow guideline used for fish passage projects in Alaska identifies the 2-year, 2-day duration flood using log-Pearson Type III for high-flow passage design criteria. Figure 3 shows a conceptual unit hydrograph for the 2-year, 2-day duration flood analysis method (Alaska Department of Transportation and Alaska Department of Fish and Game 2001).

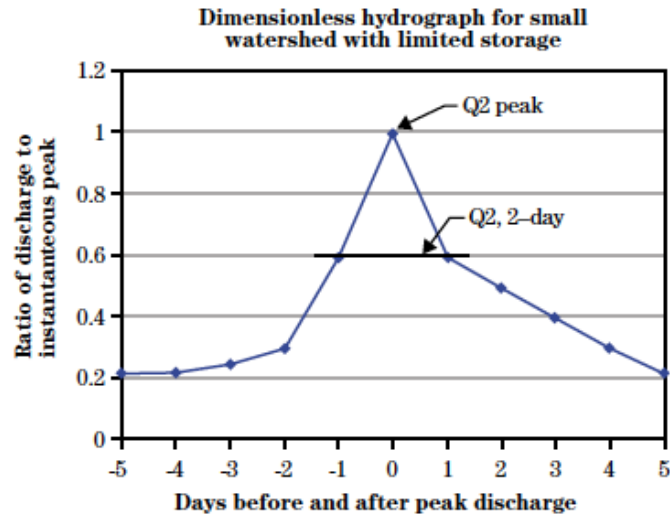

Figure 3. 2-year, 2-day duration design discharge

Fish migration upstream may be limited during peak flow events, although migration patterns vary across species. Many fish migrate during spring or winter runoff events, sometimes following high-flow freshets or influxes of freshwater that affect water quality (salinity, turbidity, temperature). In the Pacific Northwest, winter steelhead and spring chinook spawning migrations overlap flood seasons, while coho and sockeye migrate at much lower flows in the fall. It is therefore important to understand both the flood and baseflow characteristics, if migration for the species of interest occurs during these periods.

3. Hydrologic analysis for gaged streams

Hydrologic analysis techniques for characterizing flow during a specific period of interest or season usually involves flow-duration analysis of gage station data. Flood frequency recurrence analysis is typically performed using the guidelines in U.S. Water Resources Council (WRC), 1981, Guidelines for Determining Flood Flow Frequency, Bulletin #17B. Developing a flood frequency curve provides the designer with an estimate of flood magnitude and recurrence intervals for use in determining the size, configuration, and orientation of a fish passage facility. Computing flow duration is essential in determining the performance of a passage or screening structure across its operational range of flows. Flow-duration analysis is often performed by using daily average flow (or other periods such as 3-day, 5-day, or weekly) during the period of interest. A more detailed description of flow duration analyses is provided in NEH654.05.

4. Hydrologic analysis for ungaged streams

Often, gages are not sufficiently close to a project site or located within the same river system. Several methods are available to the designer for determining the magnitude and recurrence interval of seasonal high flows in ungaged watersheds. These include regional regression equations, discharge correlation to adjacent gaged streams, or development of hydrologic rainfall runoff models.

The U.S. Geological Survey (USGS) has regional regression equations for estimating flood events based on watershed area, annual precipitation, and regional variables. Regression equations have been developed for many states and can usually be obtained from state USGS offices. Typically, the regression curves are in the form identified in equation TS14N-1.

$$Q_x = aA^bP^c \quad (\text{eq. TS14N-1})$$

where:

- Q_x = x-year peak flood discharge (10-yr flood)
- a = regression constant related to basin parameters
- A = watershed area
- b = regression exponent related to basin parameters
- P = annual precipitation
- c = regression exponent related to rainfall characteristics and annual recurrence event

The designer can also use transfer techniques to estimate flow characteristics at a project location in an ungaged stream, using the results of an analysis of streamflow data at an adjacent, gaged location. In addition, a variety of mathematical and computer hydrologic modeling systems (HEC-HMS, WinTR-20, and ArcHydro) are available to aid the designer. Depending on the hydrologic model, either single event peak flow or continuous multiple event modeling can be performed. The use of regional regression, transfer techniques, and hydrologic modeling are described in NEH654.05.

5. Hydraulic analyses overview

Hydraulic analyses are performed to evaluate flow conditions through a fish passage or screening structure. Typically, hydraulic design is an iterative process that balances available water and flow rates with site conditions and limitations, biological design criteria, and evaluation of a variety of potential hydraulic flow control structures. The following is a general overview in the approach for performing hydraulic analyses of a fish passage feature. Further description of fish screens is provided at the end of this section.

The first step in a hydraulic analysis is to characterize streamflow and morphology. Important data elements that are necessary to characterize the project site include flow patterns, velocity and depth, fish migration paths and holding pool locations, identification of potential sediment scour and deposition zones, and forebay and tailwater conditions. This information is essential in aiding a designer in selecting the appropriate location and design configuration of the fish passage facility. Field measurements and surveys are needed, particularly to determine low-flow characteristics, site geometry, and local topography.

Once stream conditions are characterized, potential fish passage design alternatives can be developed and evaluated. Fish entrances, ladders, and exits typically use flow control structures such as weirs, gates, and orifices. Two of the most critical pieces of hydraulic information in the design of a fish passage facility are flow circulation patterns above, below, and adjacent to the fishway site and water surface elevations across the range of operating flows identified in the hydrologic analysis. The following section describes models available for hydraulic analysis of stream conditions and basic equations used for design of hydraulic design of weirs, gates and orifices. A more detailed description of hydraulic analyses is provided in NEH654.06.

6. Hydraulic models

The current standard for evaluating stream hydraulics is to develop a computer hydraulic model. Several models (such as HEC–RAS) are available for predicting water surface elevations, forebay and tailwater conditions, flow and diversion characteristics, and site velocities and depths (NEH654.06). Hydraulic analysis and design is an iterative process, balancing the various criteria and design requirements of the project. Therefore, the designer should perform separate calculations of composite flow profiles due to the complex nature of the hydraulic structures associated with fish passage facilities.

Evaluating existing hydraulic conditions will provide the designer with forebay and tailwater curves used in setting the preliminary invert elevations for the fish passage entrance and exit areas. Both tailwater and forebay rating curves are required for a wide range of flows (if available) for fishway design. The difference between upstream and downstream water surface elevations at the entrance and exit is the total change in head that the feature must be designed for. Structural head is a major determinant in how much flow will likely be diverted into the fishway. Completing stream hydraulics analyses and determining the range of operational flows for a passage facility begin the design of the actual fishway.

Concrete fishways and ladders

Fishways and ladders provide migrating fish with upstream passage around or through fish passage barriers. The general function of a fish passage facility is to attract fish into the structure and step them up the gradient created by the barrier to a point upstream, where they exit the ladder into the river and resume migration. The following section contains criteria, equations, and schematics related to designing concrete fishways and ladders (fig. 4).

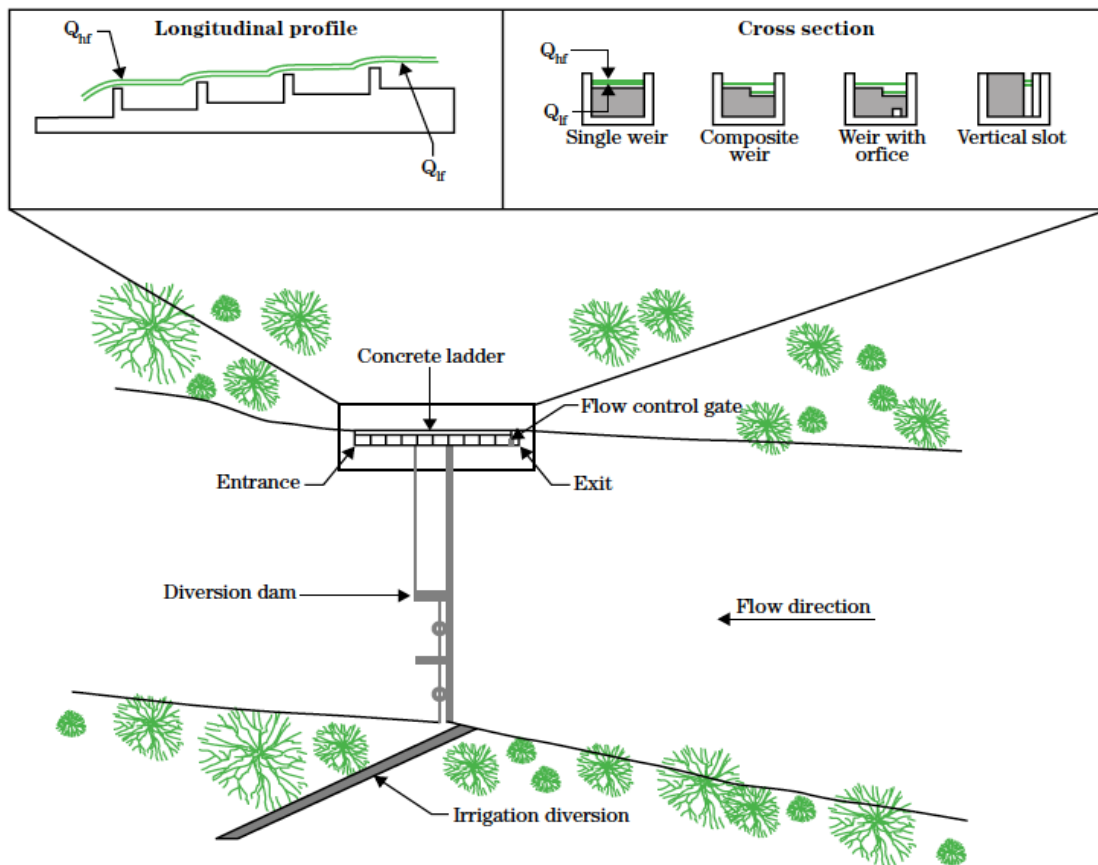

Figure 4. Plan view of a generalized concrete ladder dish passage facility

1. General overview

Fishways and ladders are constructed in many different configurations from a range of materials. Common variations include:

- excavated, earthen channels artificially roughened with large rocks
- seminatural channels equipped with stair stepped resting pools held in place with rocks, logs, or stoplogs
- concrete and/or metal structures that slow water velocity enough to provide upstream passage

These structures are designed to function across a range of flows and are often built at fish passage barriers with excessive drops or velocities. Many fishways and ladders in common use today are pool-forming structures.

Pool-forming fishways are usually constructed with concrete, metal, or dimensional lumber and can be designed to take all, or part, of the total streamflow. Partial-flow fishways are more difficult to design than full-flow fishways constructed across the entire channel. To divert only a portion of the flow, a water control structure must be included at the top (the fishway exit from a fish's viewpoint), that provides a permanent, relatively maintenance free water supply into the fishway. Pool and weir or orifice fishways are often designed with stoplogs or gates to allow adjustments to pool depth according to streamflow. Although fishways are usually more difficult to maintain proper movement of bed load and debris, they can be installed on gradients up to 10 percent.

Pool-forming fishways function similarly to natural step-pools formed by logs, rocks, or bedrock outcrops along natural stream reaches. Flows down a relatively steep channel can be governed by weirs, slots, or other restrictions that hold back part of the flow and create resting pools. Since fish are supplied resting pools along the fishway, structural length is generally not a concern.

Two common pool-forming fishways are pool and weir/orifice. Commonly referred to as fish ladders, the resting pool depth in these structures is set by the height of channel-spanning weirs or headwalls (figure 5 modified from Orsborn (1985)). Water flows over the top of a weir (pool and weir), or through a submerged orifice (pool and orifice), depending on flow rate. These structures are designed for fish that are able to jump over obstacles (pool and weir), or for non-leaping fishes, through submerged orifices at low flows. Water generally flows directly from pool to pool (rather than in a zigzag direction) to minimize energy expenditures on migrating fish. Pool and weir/orifice fishways can take many forms, but are generally useful at gradients up to 10 percent.

For juvenile and small-bodied adults, pools should be spaced no further than 15 feet with a drop of no more than 9 inches across pools. Pool spacing can be increased to 20 feet and head differential to 12 inches for adult fish.

Another type of fish ladder is a vertical slot. These structures are usually a rectangular channel made of concrete or metal in which a series of regularly spaced metal or concrete panels are installed perpendicular to the flow (fig. 6 modified from Orsborn (1985)). Each panel has a narrow slot from top to bottom and is designed to work with low velocities. Water spills from chamber to chamber through vertical slots, and pools are formed as the flowing water is backed up at each slot opening. Pool depth and velocity in each chamber are determined by slot width and the quantity of water flowing down the fishway. Although vertical slot fishways can be designed to pass a wide variety of fish species over a significant flow range, they are less passable for fish that tend to follow or cling to walls or jump over weirs. The pools of a vertical slot fishway are hydraulically complex and do not supply resting areas as tranquil as a pool and weir/orifice ladder. Consequently, these structures must be set at a low gradient to pass weak-swimming fish, although they will pass strong swimming fish at relative steep slopes. The vertical slot fish ladder transports bed material efficiently, but is susceptible to debris blockages at each of the vertical slots.

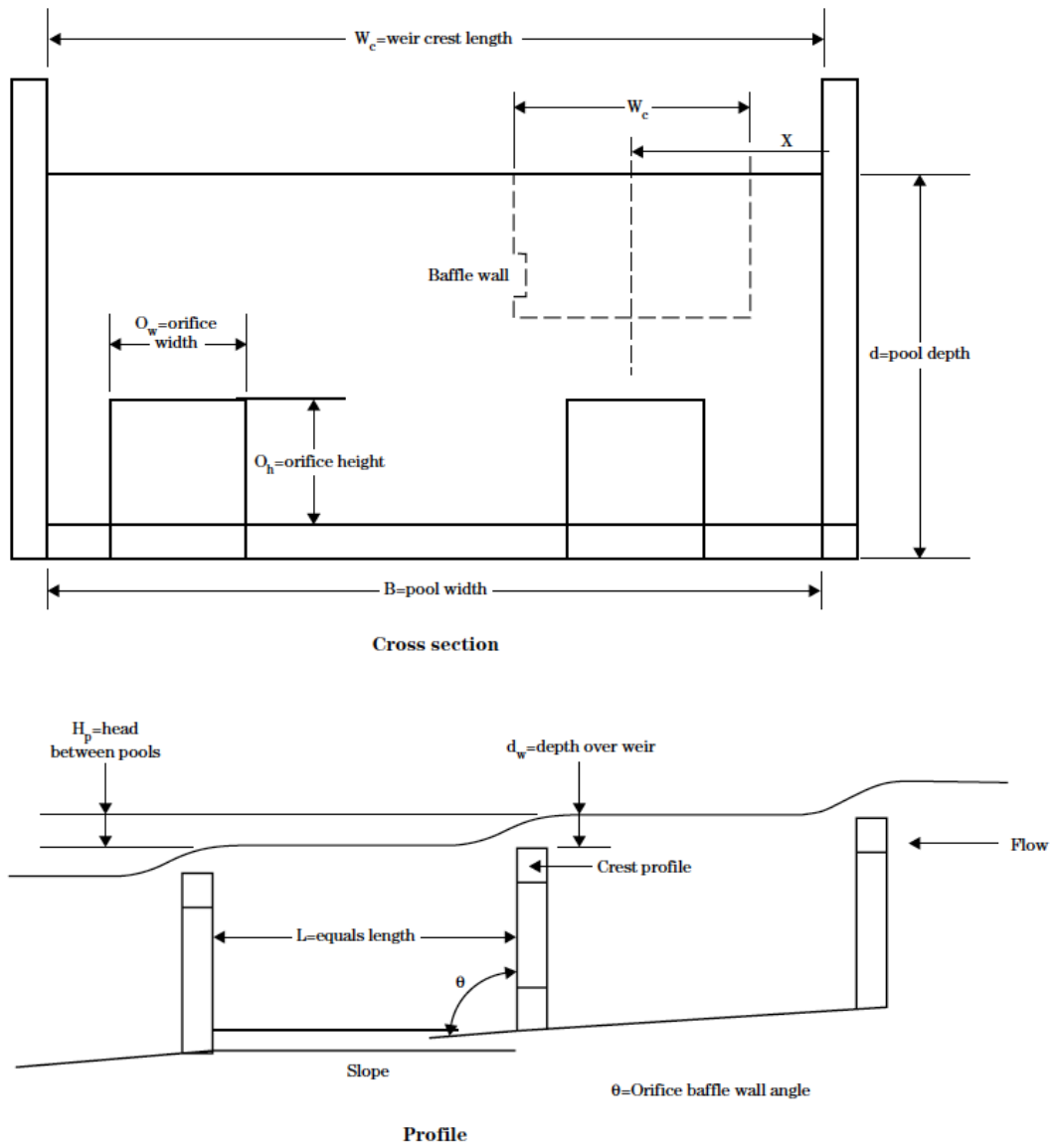

Figure 5. Cross section and profile views of a pool and weir/orifice fishway

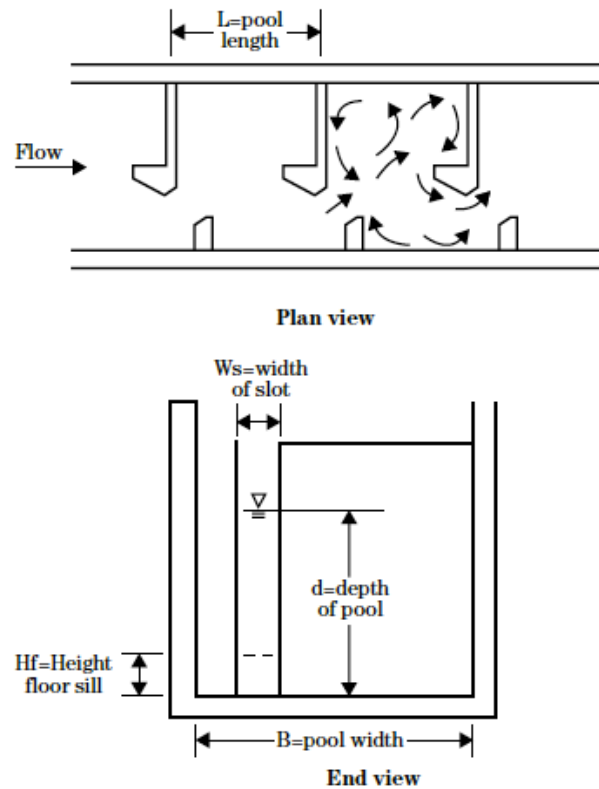

Figure 6. Plan and end views of a vertical slot fishway

2. Weirs, orifices and gates (flow controls)

Weirs, orifices, and gates are found throughout fish passage design features. The following section describes general equations and resources for evaluating flow through weirs, orifices, and gates. Specific biological considerations for the main components of the fish passage feature including the entrance, ladder, and exit follow in the next section.

General weir flow and orifice flow equations are typically in the form of equations TS14N-2 and TS14N-3 and are illustrated in figures 7 and 8, respectively. Many references provide additional information and ranges of discharge coefficients for the many types of weirs, orifices, gates, and flow conditions. Although orifice and gate equations are derived from the same general equation, the current fish passage design practice is to include orifices with weirs. A few of the references listed below provide theory and calculations for weir and orifice flow.

In addition, example solutions to weir and orifice flow equations are found at the end of this technical supplement.

- U.S. Department of Interior, Bureau of Reclamation Water Measurement Manual, 2001
http://www.usbr.gov/pmts/hydraulics_lab/pubs/wmm/wmm.html
- U.S. Department of Interior, Bureau of Reclamation Design of Small Canal Structures, 1978
http://www.usbr.gov/pmts/hydraulics_lab/pubs/manuals/SmallCanals.pdf
- International Institute for Land Reclamation and Improvement, Discharge Measurement Structures, 1978
- ISCO Open Channel Flow Measurement Handbook, 1989 (Grant and Dawson 1989)

Equation TS14N-2 is the general form of a weir equation and can be used to estimate discharge, given water surface elevation and weir height, or back-calculate water surface elevations by rearranging the equation to solve for head on the weir (fig. 7).

$$Q = C_d LH^{1.5} \quad (\text{eq. TS14N-2})$$

where:

Q = flow rate (ft³/s)

C_d = coefficient of discharge

L = weir length (ft)

H = head above the weir crest (not including velocity head) (ft)

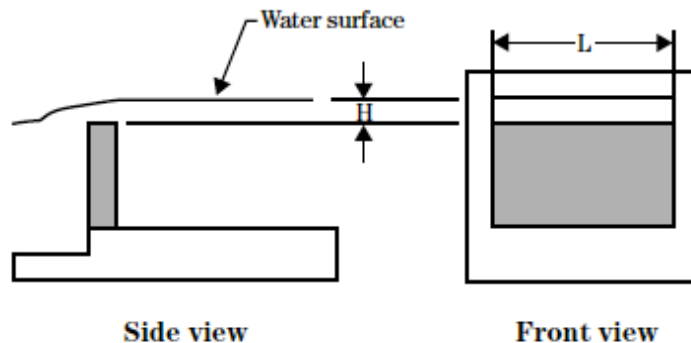

Figure 7. Weir schematic

Once the discharge or water surface elevations are determined, a back check should be performed, using equation TS14N-3, to ensure that velocity over the weir does not exceed the burst swimming speed of the target fish.

$$V_{\text{weir}} = \frac{Q}{L0.67H} \quad (\text{TS14N-3})$$

where:

V = velocity (ft/s)

Equation TS14N-4 is the general form of an orifice equation and can be used to estimate discharge, given water surface elevation and orifice dimensions (fig. 8).

$$Q = kA_o (2g\Delta h)^{0.5} \quad (\text{eq. TS14N-4})$$

where:

Q = flow rate (ft³/s)

k = flow coefficient (function of opening size and shape)

A_o = area of opening (ft²)

g = acceleration due to gravity (ft/s²)

Δh = head differential (ft)

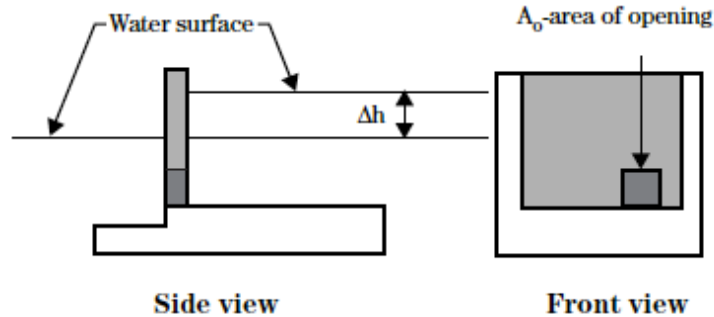

Figure 8. Orifice (gate) schematic

Again, once the discharge or water surface elevations are determined, a back check should be performed, using equation TS14N-5, to ensure that velocity over the weir does not exceed burst swimming speed of the target fish.

$$V = \frac{Q}{A_o} \quad (\text{eq. TS14N-5})$$

3. Concrete ladder pools

A final step in designing a concrete ladder system is to evaluate pool size. Pool volume should provide adequate capacity and depth to dissipate hydraulic energy, maintain stable flow, provide room for fish to accelerate and jump, and space to meet fish run capacity. Hydraulic capacity provides adequate energy dissipation so that stable, plunging flow occurs through the pool. If the pool is undersized, flow instabilities can occur in the form of surges, water fluctuations, or heavy turbulence. Pool size and shape should be configured so that fish have adequate room to accelerate and burst through openings or leap over weirs. Finally, fish capacity may be a consideration where fish runs are large enough to potentially overload the system. An overloaded fish ladder forces fish to hold in a queue until the structure can be passed. Overloaded fishways can cause significant adverse delays and should be minimized as part of the design process.

The hydraulic analysis for determining pool design configuration involves a detailed assessment of hydraulic jump characteristics. Ideally, the downstream weir is established at a height and length from the upstream weir, so that the hydraulic drop has plunging flow conditions with a fully submerged jump and no streaming flow conditions (fig. 9 (Bates 1992)).

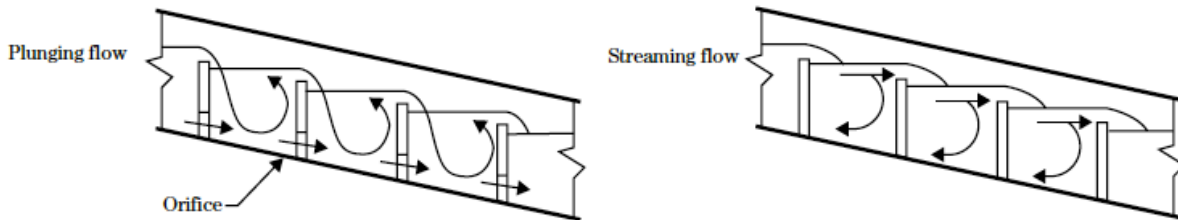

Figure 9. Plunging and streaming flow

Chow (1959) provides a method for evaluating hydraulic jump characteristics of a vertical drop (fig. 10). The general approach is to first evaluate the unsubmerged jump condition (eqs. TS14N-6 through TS14N-13), and then set the downstream weir at a height and length that forces a submerged hydraulic jump. For fish passage design, the jump is submerged by establishing the downstream weir height above the sequent depth (y_2). Downstream weir location is then set a distance beyond the drop and hydraulic jump lengths ($L_d + L_j$) to develop plunging flow.

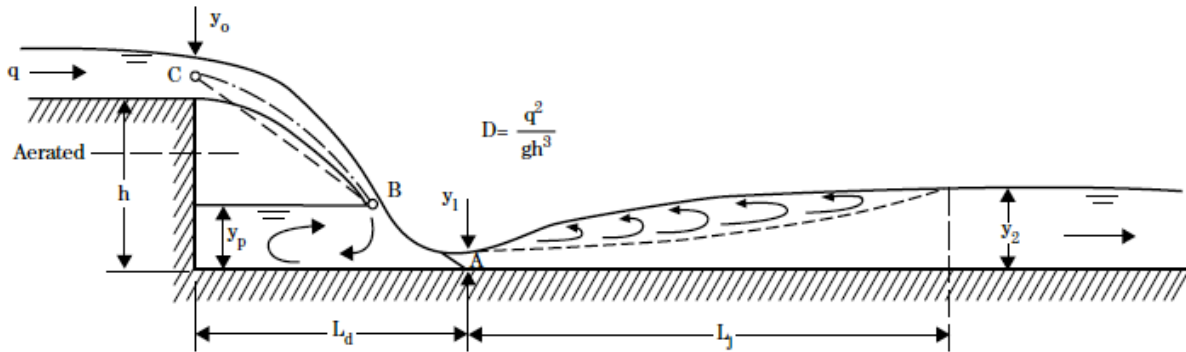

Figure 10. *D* number parameters for evaluating hydraulic jump geometry of a vertical drop spillway

The drop number (*D*) is determined using equation TS14N-6.

$$D = \frac{q^2}{gh^3} \quad (\text{eq. TS14N-6})$$

where:

D = drop number, dimensionless

q = unit discharge (ft²/s)

g = gravitational constant (ft/s²)

h = drop height (ft)

Once the drop number is determined, equations TS14N-7, TS14N-8, and TS14N-9 are used to evaluate initial jump height (*y*₁), final jump height (*y*₂), and drop length (*L*_d).

$$y_1 = 0.54hD^{0.425} \quad (\text{eq. TS14N-7})$$

$$y_2 = 1.66hD^{0.27} \quad (\text{eq. TS14N-8})$$

$$L_d = 4.3hD^{0.27} \quad (\text{eq. TS14N-9})$$

The final step is to determine the jump length (*L*_j) using equations TS14N-10 through TS14N-13 (Krochin 1961).

$$\frac{y_2}{y_1} = 0.5 \left(\sqrt{1 + 8Fr_1^2} - 1 \right) \quad (\text{eq. TS14N-10})$$

$$Fr_1 = \frac{V_1}{\sqrt{gy_1}} \quad (\text{eq. TS14N-11})$$

$$V_1 = \frac{Q}{Ly_1} \quad (\text{eq. TS14N-12})$$

$$L_j = \beta y_2 \quad (\text{eq. TS14N-13})$$

where:

Fr = Froude number, dimensionless

V_1 = velocity at the start of the jump (ft/s)

Q = discharge (ft³/s)

L = weir length (ft)

β = jump length coefficient

The jump height coefficient can be determined through empirical values shown in Table 6 (Department of Interior Bureau of Reclamation 1984).

| Channel slope | Fr ≥ 4 | 4 ≥ Fr ≥ 3 | 3 ≥ Fr ≥ 2 | 2 ≥ Fr ≥ 1 |
|---------------|--------|------------|------------|------------|
| 0.00 | 6.15 | 5.54 | 4.99 | 4.49 |
| 0.05 | 5.20 | 4.68 | 4.21 | 3.79 |
| 0.10 | 4.40 | 3.96 | 3.56 | 3.21 |
| 0.15 | 3.85 | 3.46 | 3.12 | 2.81 |
| 0.20 | 3.40 | 3.06 | 2.75 | 2.48 |
| 0.25 | 3.00 | 2.70 | 2.43 | 2.19 |

Table 6. Jump height coefficient

The next step in design is checking to ensure that the weir system is not washed out with streaming type flows and that the plunging flow condition exists (fig. 9) (Bates 1992; Rajaratnum, Katopodis, and Lodewyk 1988). Rajaratnum developed techniques for evaluating plunging and streaming flows using the following scaling equations. For plunging flows, the dimensionless discharge (Q^*) is approximately 0.61. Equation TS14N-14 is solved for the dimensionless discharge of plunging flow.

$$Q_* = \frac{Q}{\sqrt{gL^2h^3}} \quad (\text{eq. TS14N-14})$$

where:

- Q_* = dimensionless discharge
- Q = discharge (ft³/s)
- g = gravitational acceleration (ft/s²)
- L = length of weir (ft)
- h = head across weir (ft)

Another approach to determine weir flow characteristics is to check the streaming flow condition. For streaming flows, equation TS14N-15 is used to determine the dimensionless discharge. If the streaming flow condition exists, modifications to weir and pool configurations are recommended to force plunging flow conditions and provide satisfactory fish passage hydraulics.

$$Q_* = \frac{Q}{\sqrt{gSL^2h^3}} \quad (\text{eq. TS14N-15})$$

where:

- S = slope (ft/ft)

The dimensionless discharge is equal to,

$$Q_* = 0.5 \frac{L_{\text{pool}}}{h} \quad (\text{eq. TS14N-16})$$

where:

- L_{pool} = length of pool (ft)
- h = depth of streaming flow, similar to head above weir

A final design check is to evaluate pool volume based on energy dissipation criteria for the target species. Excessive turbulence and bubble formation can physically fatigue, injure, or disorient fish transiting a passage structure. Bates (1992) and WDFW (2003) suggest using the energy dissipation factor (EDF), (eq. TS14N-17), to estimate forces acting on fish in a ladder pool. EDF values greater than 4 foot-pounds per cubic feet per second for salmon and steelhead and 3 foot-pounds per cubic feet per second for shad (Larinier 1990) indicate adverse hydraulics in a ladder pool. Equation TS14N-17 can be applied to evaluate energy dissipation in pools less than 10 feet long, with an average width (for the calculation only) limited by a 4:1 side expansion from the weir opening, and pool depth at least 3h and sufficiently deep to submerge any hydraulic jump (Chow 1959).

$$\text{EDF} = \frac{\gamma Q h}{V} \quad (\text{eq. TS14N-17})$$

Energy dissipation factor (ft-lb/ft³/s)

where:

V = volume of the pool (ft³)

γ = unit weight of water (62.4 lb/ft³)

Q = discharge, ft³/s, through openings or over weirs

h = head (ft)

4. Entrance and attractors

Fish passage entrance design is a critical element of any fishway. The primary design goal is to site and configure the entrance so that it attracts fish into the passage channel by mimicking the hydraulics and morphology of natural analogs (waterfalls, cascades, log overpours). Traditionally, migrating fish seek and swim towards or alongside stream lines of higher velocity. Consequently, a fishway entrance must consider natural migration patterns along the river, as well as turbulence, velocity patterns, and dead spots that distract fish from entrance attraction flows. Designers should also account for holding patterns and migration routes, such as along the Bankline of the river, and place the fish passage entrance proximate to these features. Field observations should include mapping flow patterns and velocity vectors to help identify and prioritize entrance locations. Dam spillways and penstocks significantly influence hydraulic velocity fields and affect the performance of the fish passage entrance. In these settings, it is critical that the fishway entrance focuses flow into a jet of higher velocity water that cleanly penetrates the tailwater and attracts fish (Bates 1992).

Fish passage entrances can be overflowing weirs, orifices, or vertical slots. Ultimately, fishway entrance design is a balance between attraction velocity and maximum head for the fish to swim against, while also accounting for behavioral and migration patterns. Additional fish attractors, including auxiliary flows and pumped jets of water, are included in some fish passage features. However, these hydraulic features can also distract fish from entering the passage facility at the right location. Designers should be aware of both attractors and distractions near fish passage entrances and ensure that all distractions are eliminated from the entrance area. The following are useful criteria for fishway entrance location and hydraulics:

- The fishway entrance should be at the upstream-most point of fish passage adjacent to a barrier. Do not place fish passage facility entrances in turbulent areas.
- Provide adequate trash racks.
- Align low-flow entrances perpendicular to tailwater flow.
- Align high-flow entrances 30 degrees downstream off perpendicular to tailwater flow to help with flow penetration.

- Attraction velocities should be from 4 to 8 feet per second, preferably closer to 8 feet per second.
- Cross velocities should not exceed 2 feet per second.
- Auxiliary water velocities should be between 0.5 and 1.0 feet per second when pumped into the entrance chamber of a fishway.
- Approach flow should be parallel to the axis of the fishway entrance or at least no greater than 30 percent to the axis of the main current.

Design and build fishway entrances to provide access across changing water surface elevations such as the tailrace of a hydropower facility or the low- and high-flow elevations of a natural stream.

5. Exit

The primary design considerations for the fish passage exit are headwater and flow diversion control, maintenance of diversion design discharges during fluctuating headwater conditions, protection from debris, and alignment with migration pathways to ensure that fish find their way upstream from the passage barrier. It is also important to locate the exit far enough upstream from the crest of the dam so that fatigued or disoriented fish do not fall back downstream. Typically, fish need to acclimatize and orient themselves to the river after traveling through the fish passage facility.

Oftentimes, the fishway exit is also used to divert and regulate streamflow into the passage structure. Gates, stoplogs, tilting weirs, and other combinations of slots and orifices are often used as flow control devices. The following list provides useful considerations for fishway exit conditions:

- Place exits away from spillways, powerhouse intakes, or other hydraulic structures that pose risk of harm to target species.
- Place exits in areas of positive flow to avoid stagnant, low-quality water.
- Design and build exit with adequate trash racks.
- Include adequate structural freeboard into a fishway exit to protect it from flood damage.
- Build the fishway exit so that it can be dewatered for maintenance and inspection.

The length of the exit channel upstream should be a minimum of two standard ladder pools.

6. Rock fishways

The use of rock weirs and step-pools as fish passage features is a viable option in stream systems with large cobble to boulder channel beds. Use of rock emulates natural step-pool sequences, cascades, riffles, rock aprons, and log sills that fish naturally migrate past. They are typically more visually appealing than concrete and, in some cases, may be more cost effective (fig. 11).

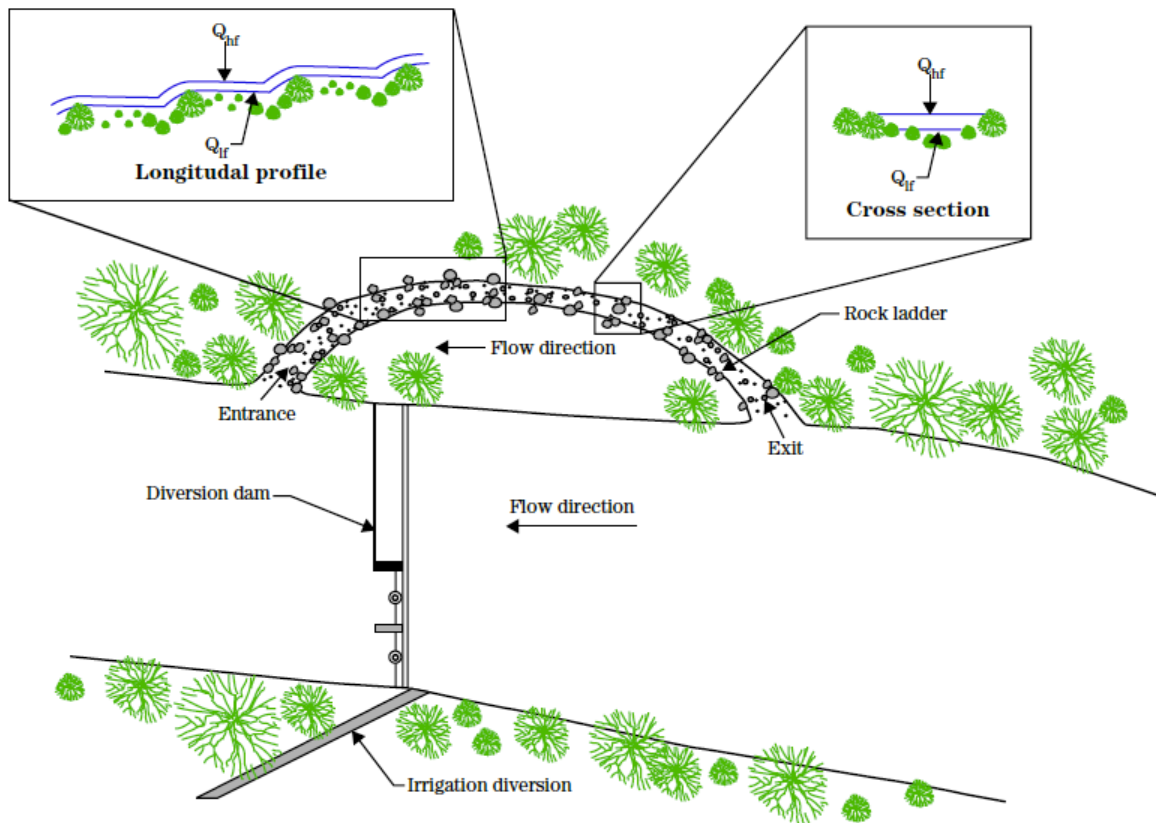

Figure 11. Plan view of a generalized roughened rock channel/rock ladder fishway

Rock ladders have the same general features (entrance, ladder, and exit area) as concrete ladders, and many of the equations that are applied to designing concrete ladders can also be used to evaluate rock ladder performance. However, additional analyses are required to account for increased energy losses and turbulence induced from the uneven shape and placement of boulder and cobble materials. Hydraulic models should be developed to evaluate water surface profiles through rock ladders, especially when no structures are included to control flow rates into the fish passage channel, entrance, and exit areas. Flow control structures can be incorporated into the design to limit the amount of flow diverted into the fish

passage channel. If not, the rock fishways must be designed to withstand a range of flows throughout the year, rather than diversions made only during fish migration seasons. A flow control structure may be necessary to protect the rock ladder from flood flows and provide adequate head to diversion facilities at low-flow conditions.

Much of the information available for designing step-pool features is related to studies performed on boulder and rock grade control weirs. These types of designs can be adapted to meet biological design criteria for fish passage. A rock ladder has three main components: a boulder, rock or cobble weir; scour or plunge pool; and tailwater area (fig. 12).

Boulder and rock weirs

Special design and analysis considerations are required when evaluating flow conditions over rockweirs, boulder sills, and along step-pool sequences. Figure 12 is a schematic of the general elements associated with a boulder weir-step-pool. Compared to standard weirs, rock weirs significantly influence turbulence, resistance, energy losses, and water surface elevations. Although empirical equations for standard smooth-crested weirs are good as a first approximation, several modifications are required to more accurately evaluate flow hydraulics in boulder weirs.

Evaluating a boulder weir incorporates hydraulic theory associated with weir length modifications and flow contractions. Weir length is determined by measuring and adding together incremental distances between the boulders (fig. 13) and adjusting for each of the side wall contractions. The basic weir equation is then modified using equation TS14N-18 (Chow 1959).

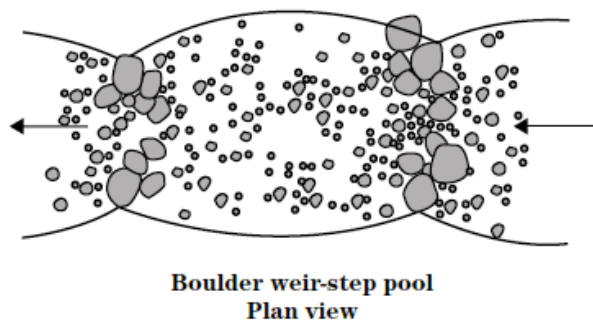

Figure 12. Boulder weir (plan view)

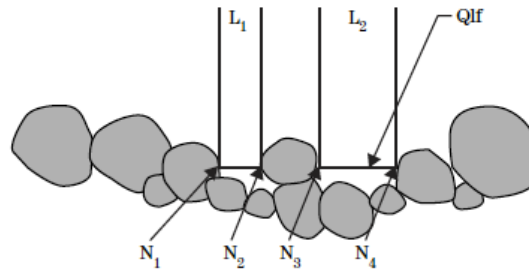

Figure 13. Boulder weir cross section

$$Q = C_d \left(\sum_i^N (L_i - 0.1NH) \right) H^{1.5} \quad (\text{eq. TS14N-18})$$

where:

- L_i = incremental widths (ft)
- N = number of contraction sides

Boulder pools

The next step in evaluating boulder and rock weirs is to determine scour depth below the drop (fig. 14). Scour depth determination should be done for the highest design discharge expected at the site location. As an initial estimate, scour depth below the bed of the channel should be equal to the drop height from the water surface to the bed surface along the tailwater area. Several scour equations are available, although the most appropriate are plunge scour functions for vertical drop structures. Equation TS14N-19 (Jager 1939 in Simons and Senturk 1992) is derived from empirical analyses of scour downstream from grade control structures.

$$Y_s = 6\Delta h^{0.25} q^{0.5} \left(\frac{Y_d}{D_{90}} \right)^{\frac{1}{3}} \quad (\text{eq. TS14N-19})$$

where:

- Y_s = depth of scour (m)
- Y_d = downstream depth of flow (m)
- q = unit discharge (m³/m-s)
- D₉₀ = sediment diameter with 90 percent of material finer (mm)
- Δh = difference in head between upstream water surface and downstream water surface (m)

$\frac{1}{3}$

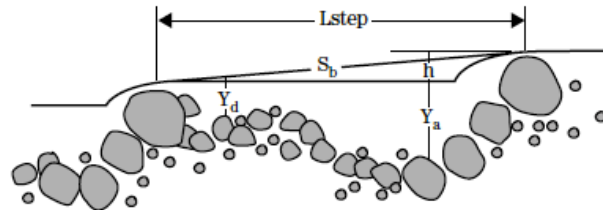

Figure 14. Boulder step-pool profile

Step-pool length is the final geometric element evaluated in designing a rock pool feature. Pool length and volume in boulder weirs is directly related to the EDF described in the previous section (eq. TS14N–17) and has a similar effect on fish passage success. Pool length equations from the previous section should be used as a first estimate. A second method to estimate pool length involves examining natural step-pool geometry and spacing in the same river system. The goal in designing a step-pool feature is to allow the fully turbulent flow jet to dissipate. Comiti (2003) reports a range of step-pool lengths based on head, channel slope, and scour depth listed in equations TS14N–20 and TS14N–21. Ratios in natural systems for pool drop to scour depth typically range between 1.0 and 2.0 for slopes greater 15 percent. However, as the slope flattens (less than 15%), step lengths to scour hole depth ratios typically begin to approach 3.0.

For slopes between

$$0.05 < \frac{h}{L} < 0.50 \quad (\text{eq. TS14N-20})$$

The drop to scour ratio is

$$1.0 < 1 + \frac{Y_s}{h} < 3.0 \quad (\text{eq. TS14N-21})$$

Rock sizing

The final design element for step-pool rock ladders is substrate sizing. Overall, the rock along the ladder must be designed to withstand the entire range of flow conditions. Designers should identify a safety range based on the accuracy of the design hydrology, hydraulics, and other site conditions and apply this range to subsequent rock size estimates. The primary design elements requiring rock sizing are the weir structure, plunge pool scour apron, and tailwater area.

Typically, rock weirs are comprised of boulders with interstitial cobbles. The boulder and rock features must be sized to withstand the highest expected flow event and provide openings and passage paths for fish during the migration period. Forces acting on the boulder and cobble rock on the weir crest include drag, lift, weight, and frictional resistance. Structural rock remains stable and in place, as long as weight and frictional resistance are greater than drag and lift forces. Equation TS14N–22 can be used to estimate minimum rock diameter on a boulder weir crest for fully turbulent flow over a rough horizontal surface, with completely submerged rock and similar submergence along both faces of a weir. The major difficulties in using equation TS14N–22 are estimating the friction slope and verifying the assumption that similar submergence occurs on all sides of the rock. Friction slope is difficult to determine over a drop, but an estimate can be made using equation TS14N–9 for drop length. A general rule of thumb is that the rock size should be greater than the drop height. Another general criterion is that the final step-pool at the downstream end of a sequence should have a buried armor layer along the entire length of the step that is similarly sized to the weir and toe protection material.

$$D_{\min} = \frac{(18(0.67H)S_f)}{(G_s - 1)} \quad (\text{eq. TS14N-22})$$

where:

D_{\min} = minimum boulder median diameter (ft)

H = depth of flow over weir (ft)

S_f = friction slope (ft/ft)

G_s = specific gravity of rock (~ 2.65)

Rock size required along a weir crest can be determined using equation TS14N–23 when velocity acting on the weir structure is known (a function of crest height and the drop into a scour hole area). In addition, velocity (V_1) can be compared to the rock sizes shown in table 7 for guidance (Fischenich 2000). Designers are encouraged to perform more thorough calculations that refine friction slope and energy losses across the boulder weir and evaluate other factors affecting rock stability (countersinking rock to resist hydraulic forces).

Sizing rock for toe protection along the scour hole across the downstream face of a weir is largely done according to previously described methods. Rock diameter can be estimated using equation TS14N–23 (Department of Interior Bureau of Reclamation 1984; USACE 1994f) and table 7. In areas subject to toe scour, the resultant vector should be used with horizontal and vertical velocity components. In a step-pool sequence with a flat tailwater bed slope, the horizontal velocity (V_{weir}) can be used. If the channel bed between the scour hole and next weir drop is not flat, the resultant vector should be used to size the bed material in the sloped tailwater area.

| Class name | Median diameter (in) | Critical velocity (ft/s) |
|--------------------|----------------------|--------------------------|
| Large boulder | >40 | 19 |
| Medium boulder | >20 | 14 |
| Small boulder | >10 | 10 |
| Large cobble | >5 | 7 |
| Small cobble | >2.5 | 5 |
| Very coarse gravel | >1.25 | 3 |

Table 7. Incipient motion thresholds for rock sizes

As a first approximation, the D_{50} can be assumed to be one to two times the size of the drop height of the structure. The velocity (V_1) can be approximated using equations TS14N–24 and TS14N–25 and equation TS14N–3 to estimate the weir velocity (V_{weir}) in the horizontal plane. Equation TS14N–26 is used to specify the size gradation of riprap and stone for weir and scour hole protection areas.

$$D_{50} = \left(\frac{V_1}{2.57} \right)^2 \quad (\text{eq. TS14N-23})$$

where:

D_{50} = median diameter (in)

V_1 = velocity (ft/s)

$$V_1 = \sqrt{V_{weir}^2 + V_y^2} \quad (\text{eq. TS14N-24})$$

$$V_y = \sqrt{2g\Delta h} \quad (\text{eq. TS14N-25})$$

$$1.7 < \frac{D_{85}}{D_{15}} < 2.7 \quad (\text{eq. TS14N-26})$$

Exposed bed material in the tailwater area of each weir pool should be sized using weir velocity (V_x) and equation TS14N-3 solved for the horizontal plane. This element of the boulder pool sequence provides protection for the upstream approach of the next downstream weir.

Rock sizing calculations are addressed in more detail in NEH654 TS14C, and grade stabilization structures are described in NEH654 TS14G.

Roughened channel fishways

Roughened channel fishways function similarly to steep, boulder-strewn, cascading stream reaches. These chutes or flumes contain roughness elements to break up streamflow and reduce water velocity. Roughened channels, unlike pool-forming fishways, do not create deep pools where fish can stop to rest before jumping or swimming to the next step. Instead, target species must use prolonged or sustained swimming speed to transit the entire length of the structure, with minimal or no resting. This same concept makes a baffled culvert more passable than a corrugated metal pipe which, in turn, is more passable than any smooth pipe (see description of culverts in next section). Roughened channels must be designed with careful consideration for the swimming capabilities of target species, and overall fishway length should be kept to the minimum possible for prevailing site conditions.

1. Engineered channel

An engineered channel is a roughened waterway that is an excavated earthen channel or a natural stream channel lined with a series of boulders that are properly sized and placed for site streamflow and gradient. Roughness elements, commonly boulders or concrete blocks, are anchored in place where stream flows are high or gradients are steep. At slopes up to about 5 percent, roughness elements can be embedded into a cobble and gravel streambed; for slopes between five and 9 percent, they must be anchored into a concrete channel subgrade. Strategic placement and anchoring of rocks or concrete blocks into modified natural stream channels can significantly improve passage conditions. Maximum engineered channel length depends on the swimming abilities of the target fish. A boulder and rock weir fishway (or fish ladder) is required if site conditions dictate a long-engineered channel that likely exceeds the known swimming abilities of the target species.

Engineered, steepened channels are designed to survive very high flows, are easily maintained, and cost less to build than concrete fishways. Guidance for designing these fishways can be found in previous chapters. There are no standard empirical methods to predict passage using this informal method, so they cannot be built with gradients as steep as roughened channel fishways. However, the geometry of natural analogs in the same stream system (cascades or bedrock chutes) can provide designers with insight into structural limitations at a given project site.

Engineered channels have been successfully used in some Midwestern states to pass warm-water fishes such as redhorse, walleye, northern pike, and various minnow and sucker species. Commonly referred to as rock ramps, these structures have been in use for several years to provide fish passage at low head dams (fig. 15). Rock ramp fishways can also provide additional protection against undermining from toe scour caused by water spilling over the face of a dam.

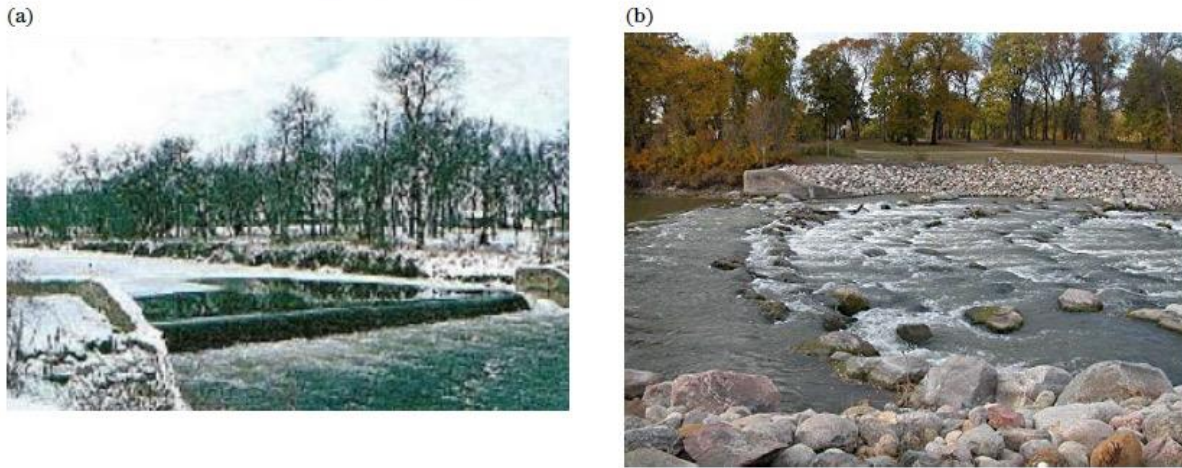

Figure 15. (a) North Dam on the Red River of the North (ND) before construction; (b) after construction of an engineered channel fishway

2. Denil

Made from wood, steel, and/or concrete, a Denil fishway is a rectangular channel fitted with a series of symmetrical, closely spaced baffles that redirect flowing water and allow fish to swim around or over a barrier (fig. 16). The figure on right is modified from Powers et al. (1985). Baffles placed on the floor or walls of the relatively steep, (10 to 25% slope) rectangular flume reduce mean flow velocities to ranges negotiated by migratory fish. Denil ladders generally do not have resting areas, although pools can be included in the design to provide resting areas or velocity reductions. Further, switchbacks can be added to minimize the footprint of the structure. When small-bodied or weaker swimming fish are targeted for passage, Denil ladders can be built at a shallower slope with smaller baffles, or closer baffle spacing, to minimize physiological exertion.

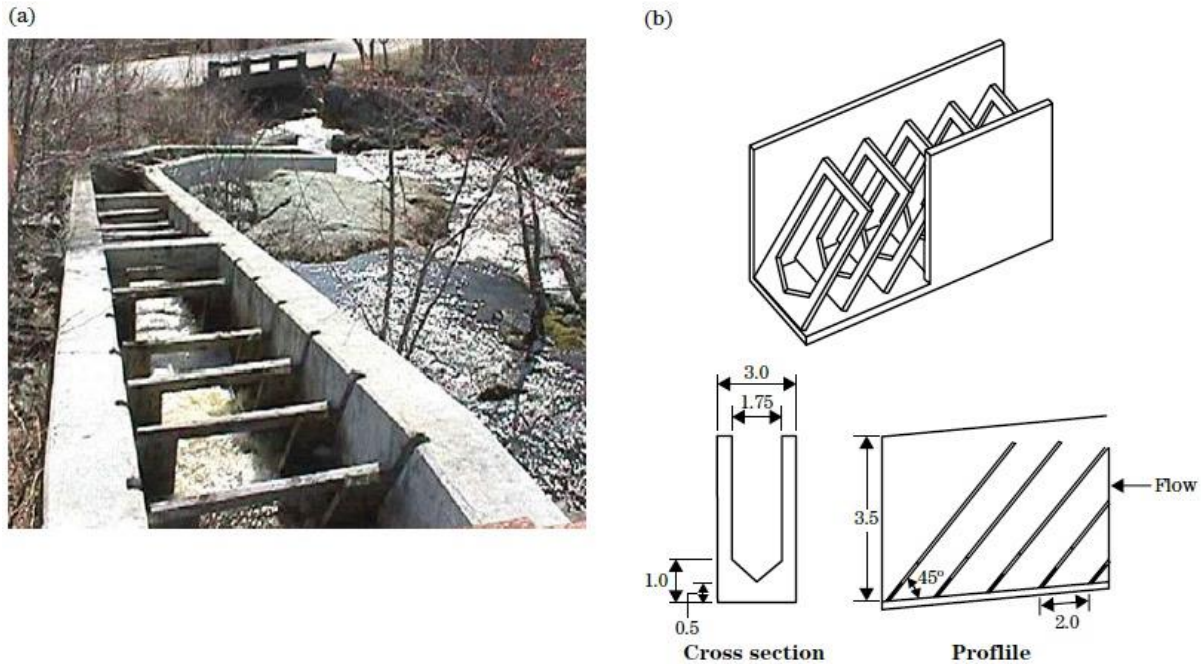

Figure 16. (a) Site photo; (b) schematic of a common Denil fishway

Many different Denil fishway designs are presently in use. The most common, the plane baffle or standard Denil fish ladder, is composed of baffles angled up from the floor at 45 degrees and spaced between 2 and 4 feet. Standard Denil ladders are commonly applied at slopes between 15 and 20 percent. Another frequently seen approach uses herringbone-patterned baffles made of thin steel attached only to the bottom of the flume; the two sides of the channel remain smooth. Although the width of this design is generally not limited, the maximum applicable slope is about 15 percent.

All Denil ladder applications are susceptible to damage from debris, as well as debris accumulation. They are generally most applicable in settings where water surface elevation fluctuations are 1 foot or less. Denil fishways only provide adequate fish passage conditions under a narrow range of flow. Consequently, adequate flow control at the upstream opening is essential for successful operation and fish passage.

3. Alaska Steeppass

Alaska Steeppass fishways, a variation of the Denil ladder, are prefabricated, modular, and usually constructed of a lightweight material like aluminum (fig. 17). The figure on right is modified from Powers et al. (1985). These factors make the Alaska Steeppass relatively economical to build, install, and use, especially for temporary applications or in remote locations. The Alaska Steeppass has a more complicated baffling system than a Denil fishway, but this design controls water more efficiently and allows installation and operation at slopes up to 35 percent. In addition, internal baffle design permits the Alaska Steeppass to successfully operate at lower flow rates than a Denil ladder. However, generally smaller inlets and complicated baffles also make steeppasses more susceptible to debris problems than common Denil ladders. Flow control is also critical for these structures, and headwater range generally cannot fluctuate more than about 1.5 feet without creating passage difficulties.

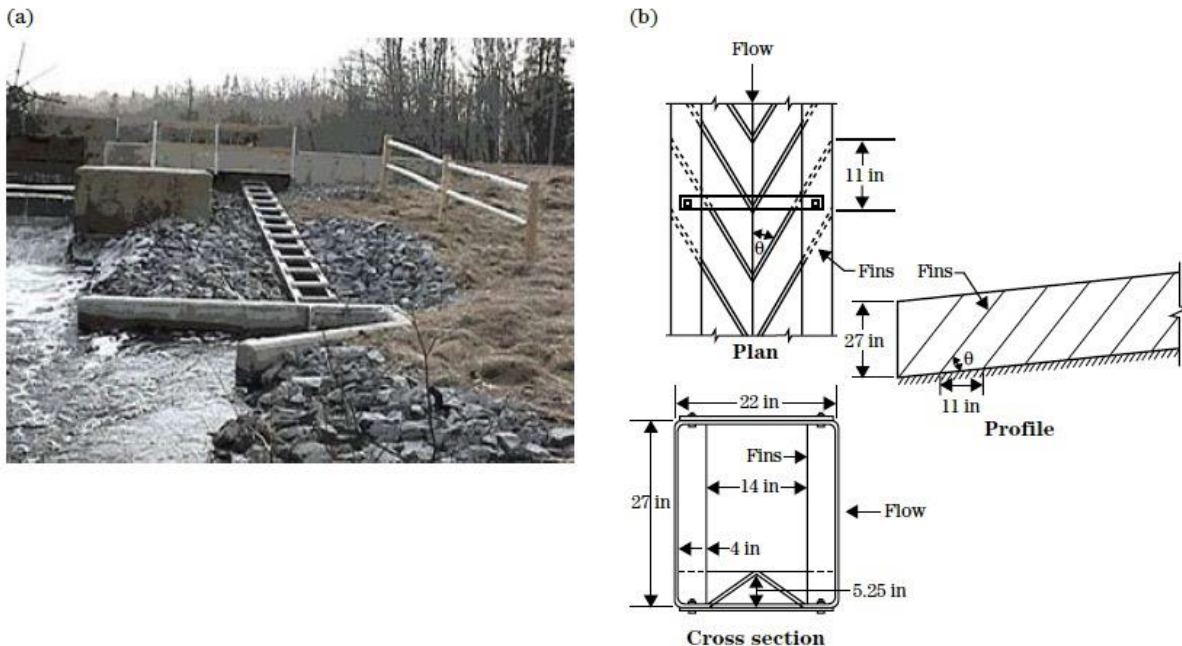

Figure 17. (a) Site photo; (b) schematic of an Alaska Steeppass fishway

Baffle design in an Alaska Steeppass can be adjusted to fit the passage needs of target species. Although the floor fin angle (ϕ) is generally 45 degrees, side fin angle (θ) adjustments from 45 to 90 degrees are commonly used to reduce air entrainment and structural turbulence to improve passage conditions.

4. Culvert modification and design

Culverts may be the most common artificial barriers to upstream fish passage. Although usually associated with road crossings, they are also found under railroad grades, pipeline crossings, irrigation canals, buildings, and parking lots. Culverts are usually round, rectangular, elliptical, flat-bottomed, or bottomless, and are often made from steel, concrete, or plastic (PVC, ABS). Their interiors can be relatively smooth, but are often roughened by streambed substrate and/or corrugations. Culverts create fish barriers in one or more of the following ways:

- high velocities or sudden velocity changes at the inlet or outlet or inside the culvert barrel
- inadequate flow depth in the culvert barrel during critical migration periods
- excessive length without adequate resting areas
- significant drop at the culvert outlet
- debris accumulation at the culvert inlet, outlet, or inside its barrel
- excessive turbulence inside the culvert or at its outlet or inlet

This section on modifying or installing culverts to provide fish passage relies heavily on results of fish passage studies, field applications, and information published by a team of engineers and biologists from the Washington State Department of Fish and Wildlife. Their work, *Design of Road Culverts for Fish Passage* (WDFW 2003), is commonly cited in fish passage regulations and studies across the United States. The following sections provide a general overview of options for designing, installing, or modifying new or existing culverts for fish passage.

Modifications to existing culverts

Generally, an unblocked culvert with an outfall greater than 0.8-foot, diameter 50 percent of bank full channel width or less, and slope greater than 1 percent should be considered as at least a partial barrier to migratory fish. Short of replacement, culverts can be modified in a number of ways to improve fish passage. For example, perched culverts are usually undersized and relatively steep, and over time, the channel bed often drops, leaving the outlet lip many inches or feet above the water surface elevation of the downstream pool (fig. 18). If site conditions allow, fish passage at a perched culvert can be improved by raising the culvert outlet pool water surface elevation with a channel-spanning structure or series of structures (fig. 19).



Figure 18. A significantly perched culvert



*Figure 19. Series of channel spanning weirs used to step up water surface
and raise outlet pool to culvert lip*

Excessive velocity and shallow-flow depths also impede fish passage in existing culverts—this condition is especially common in concrete box culverts. Retrofitting a culvert with baffles may improve fish passage across a range of flows, but only where site conditions allow. Placing baffles within a culvert may reduce capacity of the culvert by an unacceptable amount. Baffles are a series of features that increase hydraulic roughness inside the barrel of a culvert

(fig. 20 (modified from WDFW (2003); variables shown are defined in their appendix D)). Unlike hydraulic control structures (weirs), which independently reduce velocities, baffles work together to reduce the average cross-sectional velocity throughout the length of a culvert.

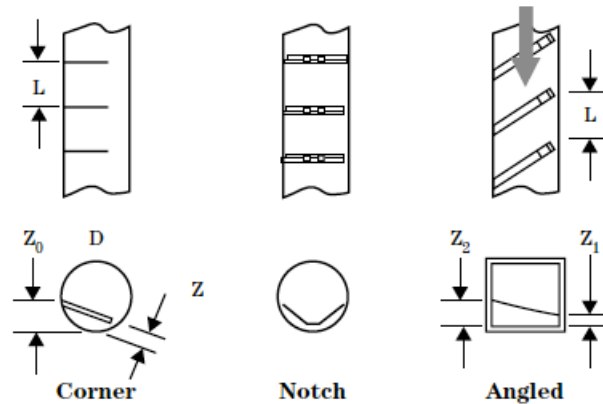

Figure 20. Common baffle styles for round and box culverts

Installing baffles into a culvert should only be considered as a temporary solution to improve fish passage. Adding baffles reduces hydraulic capacity, generally increases the risk of failure from flooding conditions, and makes culverts more prone to capture debris and bed load. Baffled culverts require maintenance, so the barrel diameter should allow at least 5 feet of headroom for crews to safely work inside. Proper and frequent maintenance of culvert baffles is essential to ensure that a modification made in the name of improving fish passage does not result in poorer conditions than existed prior to the retrofit.

Installing baffles alters the hydraulics of a culvert and requires a good knowledge of the flow characteristics of the subject stream. Baffles installed near the inlet of a culvert should be placed at least one culvert diameter downstream at a height that will ensure subcritical flow at high discharges. Baffle systems like those shown in figure 20 should only be installed in culverts with slopes no greater than 3.5 percent. Corner baffles are generally used in culverts with slopes between 1.0 and 2.5 percent and are intended to provide wall roughness, while minimizing debris blockage potential (fig. 21). Notch baffles can be applied in culverts with slopes between 2.5 and 3.5 percent, but are designed to function as weirs at slopes greater than 3.5 percent.



Figure 21. Round, corrugated metal culvert retrofitted with corner baffles to improve fish passage

Culvert replacement or installation

Replacing existing culverts or installing new road crossings can challenge the engineer and fisheries biologist: a hydraulically efficient culvert often poses a barrier to fish passage because of the inherent hydraulic differences between supercritical and subcritical flow. Standard culvert hydraulic and structural analyses apply. Fish passage requires more data to be considered. However, the three replacement and installation options described provide approaches that often balance resource constraints and needs in an economical manner. Still, culverts may not always provide adequate fish passage, and other more invasive and expensive options such as rerouting a waterway or building a bridge may require consideration. Road abandonment can be an option if a culvert barrier to fish passage is along a poorly maintained and/or unused road.

The no-slope, stream simulation, and hydraulic design approaches to culvert replacement and installation are a mixture of standard methods and new advances in fish-friendly culvert design. The no-slope and stream simulation options are favored over the hydraulic design approach, but project and site-specific conditions will affect which method and outcome is selected. An overview flowchart of culvert criteria and a general design process is presented in figure 22 (modified from WDFW (2003)).

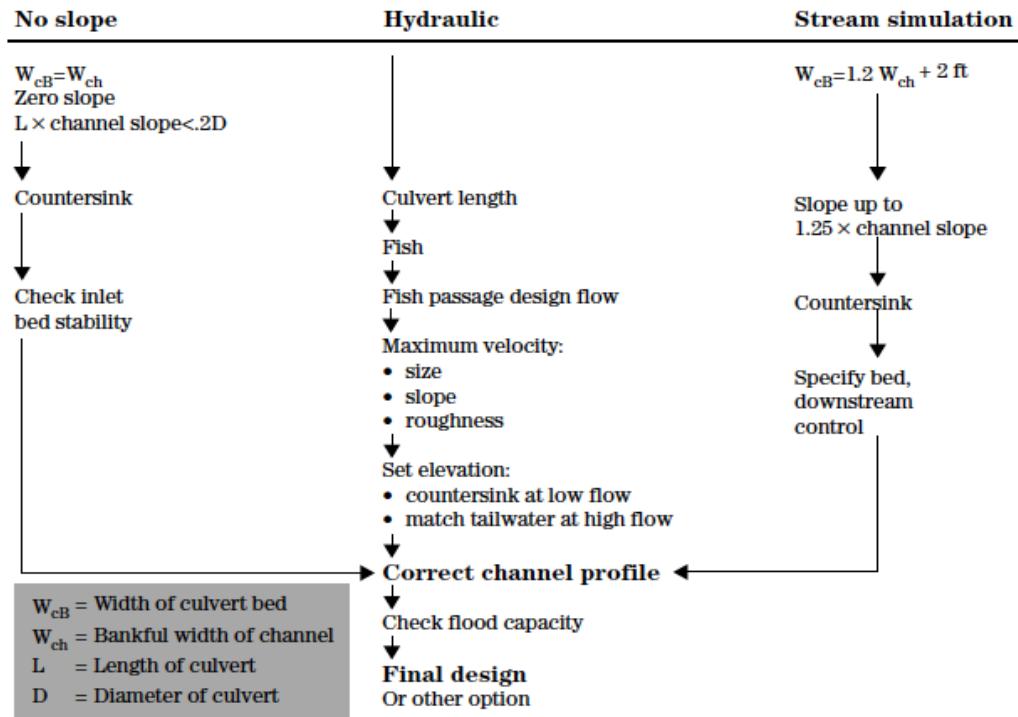

Figure 22. General flowchart of culvert design process

No-slope option

The no-slope design approach is founded in the assumption that a sufficiently large culvert installed at grade will allow the natural movement of bed load and formation of a stable bed inside the culvert barrel. Maintaining sediment transport continuity and the preservation of a natural channel bed inside the culvert usually provides excellent fish passage conditions across a range of flows. A no-slope culvert is defined by the following characteristics:

- width equal to or greater than the average bankfull channel width where the culvert meets the channel bed
- relatively flat gradient
- downstream invert is countersunk into the channel bed by a minimum of 20 percent of the culvert diameter (or rise, for noncircular culverts)
- upstream invert is countersunk into the channel bed by a maximum of 40 percent of the culvert diameter (or rise)
- upstream and downstream geomorphic instability (headcuts) is addressed

- adequate flood capacity exists

No-slope culverts are usually constructed where channel gradient is 3 percent or less, and culvert lengths are short to moderately long. This approach requires minimal engineering and surveying, although the following information is mandatory:

- average bank full width of the undisturbed channel (new installations and replacements)
- average channel slope (measured along the thalweg for 20 channel widths upstream and downstream of the site, especially if a perched culvert is being replaced)
- elevation of the natural channel bed at the outlet of an existing culvert (for replacements only)
- evaluation of head cut potential immediately upstream of the crossing (for installations and replacements)
- measures to protect culvert fill during floods (riprap abutments or concrete wingwalls)

A no-slope culvert can be almost any shape; however, the streambed at the site must be relatively flat because the culvert itself will be laid level with at least 20 percent of the culvert height countersunk at the outlet and with no more than 40 percent embedded at the inlet (fig. 23 (modified from WDFW (2003))). For circular pipes, height is the diameter; for noncircular (box, pipe arch, elliptical, or bottomless) culverts, it is the rise.

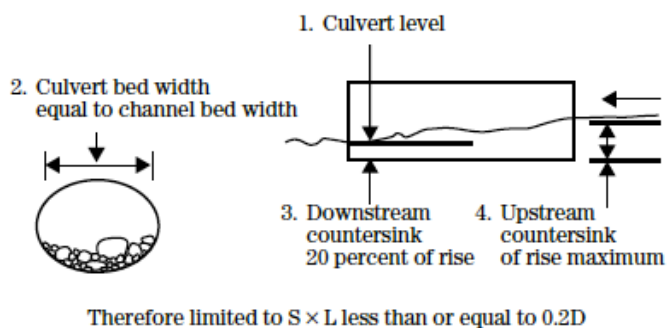

Figure 23. No-slope option culvert schematic

The diameter (circular pipe) or span (noncircular pipe) must be a minimum of 1.25 times the average bank full width. The average bank full channel should be derived from three width measurements taken in naturally straight channel reaches, within 20 channel widths upstream and downstream of the crossing or nearest hydraulic control. If an existing culvert is being replaced, it is important that all stream measurements (slope, width) are collected in reaches

isolated from any hydraulic or geomorphic influences attributable to the culvert or other unique channel constrictions. Often, impassable culverts cause the channel to become wider at the inlet or outlet or to become incised at the outlet. Further, geomorphic changes can occur many bank full channel widths upstream or downstream from a culvert until the system attains an equilibrium state or encounters a stable hydraulic control (boulder debris flow, bedrock outcrop, channel-spanning dam).

For a given span, box culvert height can be variable, but a pipe arch or elliptical culvert has only one height. Also, for a given height, a box culvert has greater hydraulic capacity than either a pipe arch or a round pipe. Pipe arches may have the least amount of flow capacity and should be used only for severe restrictions on fill height. A corrugated steel pipe is the most commonly used culvert for the no-slope option because they are less expensive and easier to install than a box culvert and have more capacity than a pipe arch or an elliptical culvert. Finally, under the no-slope option, the acceptable culvert length becomes shorter as the channel becomes steeper, especially for pipe arches (table 8 (developed by Mark Schuller, NRCS WA)).

$$\text{Maximum culvert length (ft)} = 0.2H / \text{channel slope} / 12 \text{ in}$$

where:

CW = channel bed width (bankfull: ordinary high water: active channel width) (in)

H = (1.25)(CW) = diameter of round pipe or rise of pipe arch (in)

RP = round pipe diameter (in)

PA = pipe arch rise (in)

Note: Shaded areas are culverts at least 40 feet long (typical two-lane road)

| Channel and culvert widths | | | Culvert length per channel slope (corrugated metal) | | | | | | | |
|----------------------------|-----|--------|--|-----|----|----|-----------|----|----|----|
| | | | Round pipe | | | | Pipe arch | | | |
| CW | RP | PA | 1% | 2% | 3% | 4% | 1% | 2% | 3% | 4% |
| 24 | 30 | 35×24 | 50 | 25 | 17 | 13 | 40 | 20 | 13 | 10 |
| 36 | 45 | 46×36 | 75 | 38 | 25 | 19 | 60 | 30 | 20 | 15 |
| 48 | 60 | 60×46 | 100 | 50 | 33 | 25 | 77 | 38 | 26 | 19 |
| 60 | 75 | 81×59 | 125 | 63 | 42 | 31 | 98 | 49 | 33 | 25 |
| 72 | 90 | 95×67 | 150 | 75 | 50 | 38 | 112 | 56 | 37 | 28 |
| 84 | 105 | 112×75 | 175 | 88 | 58 | 44 | 125 | 63 | 42 | 31 |
| 96 | 120 | 128×83 | 200 | 100 | 67 | 50 | 138 | 69 | 46 | 35 |
| 108 | 135 | 137×87 | 225 | 113 | 75 | 56 | 145 | 73 | 48 | 36 |
| 120 | 150 | 142×91 | 250 | 125 | 83 | 63 | 152 | 76 | 51 | 38 |

Table 8. Maximum lengths for no-slope culverts

Most common round and elliptical culverts are made from corrugated steel. Larger culverts with wider and deeper corrugations produce more flow resistance (friction) and result in slower average water velocities through the culvert. Slower velocities provide better fish passage conditions and tend to balance sediment transport by retaining bed materials within the barrel. Therefore, for fish passage purposes, bigger, countersunk culverts are always better. As a rule of thumb, WDFW (2003) suggests that 36 inches should be the minimum diameter for culverts in fish-bearing streams less than 30 inches wide.

Single, large, noncircular culverts are preferred over multiple smaller pipes at fill-limited sites because they provide better fish passage, minimize debris accumulations, and are less apt to fail during flood events. A good rule of thumb for any culvert replacement or installation is to design the road crossing so that the outlet velocity is no more than 25 percent greater than what

would have occurred at any given flow without a culvert in place. In addition, erosion and deposition upstream of the culvert can be minimized by designing for less than 1 foot of head loss during a 10-year flood event. This guideline minimizes backwater effects upslope of the culvert inlet and decreases downstream scour caused by head buildup at the inlet and resultant high velocity outflow at the culvert outlet (fire-hose effect).

Oversizing a culvert for high flows will improve debris passage and allow for easier maintenance inside the barrel. Care should be taken to armor the upstream and downstream abutments of a newly installed or replaced culvert. Finally, additional overflow culverts or hardened dips in the road prism may be necessary in watersheds that experience significantly high flows from episodic climatologic events (rain on melting snow or hurricane-driven rainfall).

Stream simulation option

As the name implies, the stream simulation approach is used to create or maintain natural stream processes within the barrel of a culvert. Stream simulation is based on the assumption that, if fish can easily swim through a natural channel, they should be able to swim through a manmade channel that simulates the natural channel. Generally, stream simulation culverts are best applied under the following circumstances:

- complex installations in moderate to high gradient channels
- longer culverts in narrow stream valleys
- culvert bed slopes that will be no more than 125 percent of the upstream channel slope
- locations where passage is required for all species (including those for which no swimming or leaping performance data exist)
- locations where ecological connectivity is of high importance or where terrestrial animals are forced to cross the road surface

Applying the stream simulation approach requires a working knowledge of the stability (both vertical and horizontal) of a prospective work site. The target stream channel must be stable within a range that can be accommodated by the planned culvert. Channels suitable for stream simulation culverts must be in equilibrium, meaning that the quantity and size of sediment delivered to the reach is roughly equivalent to the quantity and size transported out. The target stream channel must be stable within a range that can be accommodated by the planned culvert, and knowledge of vertical channel stability is essential. If the downstream channel is likely to degrade, the new culvert must be countersunk deep enough to accommodate any base level changes. Additionally, downstream grade controls are necessary to ensure further degradation will not lead to a perched culvert. Conversely, if the reach is susceptible to aggradation, the culvert must be sized to accommodate any bed-material buildup until competent stream flows occur to transport accreted sediments. If the degree of aggradation or

degradation is unknown, additional baseline data collection or alternative crossings (bridges or large bottomless arches) should be strongly considered.

Stream simulation culverts are sized wider than the active channel and filled with a mix of bed material that will promote natural sediment transport dynamics through the road crossing (fig. 24). Stream simulation culverts are most often applied at slopes between 3 percent and 6 percent, although installations have occurred in gradients up to 8 percent (WDFW 2003). This method requires the largest culverts of all approaches described (minimum of 6 ft wide) and involves either placing a bottomless arch (precast concrete, structural steel plate) over the entire width of the channel or countersinking an oversized round culvert or flat-bottomed pipe (pipe arch, precast concrete). The most basic stream simulation culvert is a bottomless arch placed over an undisturbed natural channel, allowing the streambed to remain intact and decreasing chances of geomorphic instability.



Figure 24. Undersized perched culvert (left) replaced with larger pipe designed using stream simulation option

Round, corrugated metal or concrete box culverts are preferred over pipe arches. A round pipe with a diameter roughly equal to a given pipe arch span affords a greater fill depth for the same bed and crown elevations, thus providing a vertical erosion buffer before the pipe bottom is exposed. Costs are very similar, but assembly and installation of a round pipe is easier than for a similarly sized pipe arch. Regardless of which culvert shape is used, it must be sufficiently wide and embedded deep enough (30 to 50% of culvert height) to allow natural stream processes (scour, deposition, and thalweg migration) to occur within the enclosed channel.

Properly embedding a stream simulation culvert raises the stream channel to the widest part of the pipe and creates deeper fill which can withstand greater vertical and lateral channel adjustments. The channel bed within a stream simulation culvert should not exceed a slope ratio of 1.25, defined as culvert slope divided by channel slope. Slope ratios greater than 1.25 require use of the hydraulic design method.

Stream simulation method culverts are sized according to the desired culvert bed width. Culvert bed width is the width of the bed inside the culvert, once the culvert is embedded in the channel (W_{cb}), where:

$$W_{cb} = 1.2 (\text{bankfull width}) + 2 \text{ ft (eq. TS14N-27)}$$

Notes:

Circular pipe embedded 30 percent,
culvert diameter = $1.1(W_{cb})$

Circular pipe embedded 50 percent,
culvert diameter = $1.0(W_{cb})$

Concrete box embedded 30 to 50 percent,
culvert span = $1.0(W_{cb})$

The preceding equation should be adhered to unless compelling evidence indicates otherwise. Deviations could lead to significant consequences, including inlet contraction scour, and smaller culverts will increase the chance of adverse outcomes over the design life of the crossing. If the stream is confined in a relatively narrow, stable channel, it may be possible to drop the 2-foot constant from the preceding equation. However, designing for the widest possible culvert helps ensure that terrestrial wildlife, such as turtles, small furbearers, and even deer, are also able to cross under the road.

Bed configuration within the culvert barrel should be based on channel composition in reaches adjacent to the crossing. Figure 25 illustrates two design scenarios for culvert bed composition at slopes less than and greater than about 4 percent. The 4 percent threshold is based on observations that indicate channels and culverts in streams with an energy gradient of 4 percent or less tend to have mobile beds at frequent intervals (WDFW 2003). Streams with gradients higher than 4 percent tend to have larger substrates arranged in step-pools or cascades where bed load mobility is limited except at very high flows.

The major difference between the two scenarios depicted in figure 25 (modified from WDFW 2003) concerns substrate composition and arrangement inside the culvert barrel. Culvert beds in streams with bed slopes shallower than 4 percent should be composed of native channel material with bands of larger rock to control grade and channel shape. Rock bands should be composed of well-graded rock one to two times D_{100} (the largest bed particle). The crest of each rock band should be dipped in the middle to direct the thalweg, and bands should be

spaced at the lesser of five times channel width or as necessary to provide a vertical difference across adjacent crests no greater than 0.8 feet. Bands should never be closer than two channel widths or 25 feet (whichever is less) from either the inlet or outlet of the culvert.

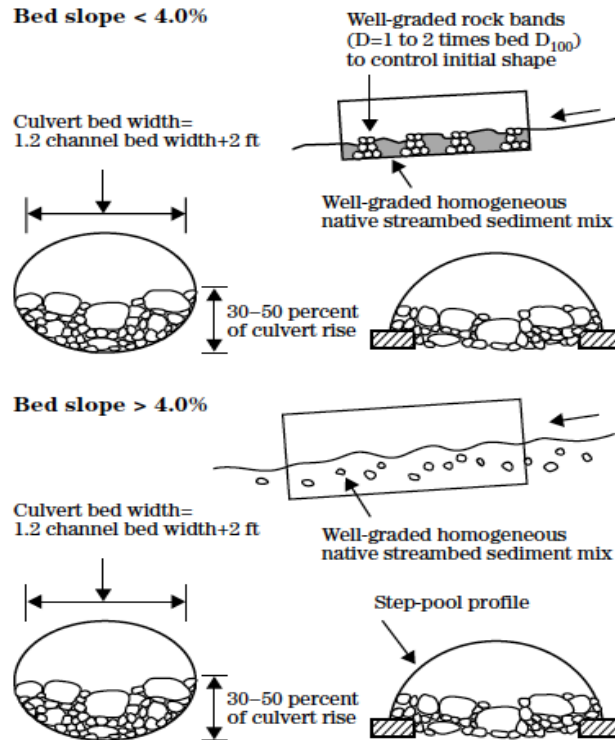

Figure 25. Low (<4%) and high (>4%) bed slope stream simulation culvert design schematics
(Note that culvert slope is similar to streambed slope)

Culvert beds in streams with bed slopes greater than 4 percent should be composed of native or engineered material arranged as a monolithic structure where the largest particles are in contact with each other. This approach forms a network of continuous support along the whole length of the culvert and depth of the fill. No grade control within the barrel of the culvert is needed since channel beds at these gradients are very coarse and stable.

Stream simulation design culverts are easiest to install where channel slope and bed material match culvert slope and bed material. Difficulties often arise as the slope ratio approaches 1.25, and the designer must pay special attention to the sizing and arrangement of fill materials

inside the culvert barrel. Under these circumstances, the designer should adhere to the following data collection, analysis, design, and construction protocol:

Stringent assessment of site suitability including:

- Slope
 - channel geometry
 - channel stability and geomorphic trajectory
 - pebble count and subsurface sediment sampling
 - hydraulic characteristics of design flows and depths
- Design sequence
 - culvert bed mix composition
 - use reference reach, incipient motion, or paleohydraulic analyses
 - intended bed gradation and configuration (rock bands or homogeneous mix of native material)
 - transitions to adjacent upstream and downstream channel reaches
- Construction
 - Ensure completed project complies with design drawings by producing as-built drawings.

Hydraulic design option

Historically, the hydraulic design option (fig. 26 (modified from WDFW 2003)) has been the standard engineering method for designing fish passage at culverts. This design method requires knowledge of the swimming ability, migration timing, and size of the target species. Design criteria are usually based on the swimming abilities or size of the weakest species of fish, where known, and usually include rigorous engineering and hydrologic calculations where site-specific data are unavailable or of inadequate duration. These culverts are often the most susceptible to future longevity, function, and maintenance problems because they are generally smaller than culverts designed by either the no-slope or stream simulation options. Designers should strive to keep culverts designed under this approach as short as possible because passage criteria are usually based on the fish's prolonged swimming speed.

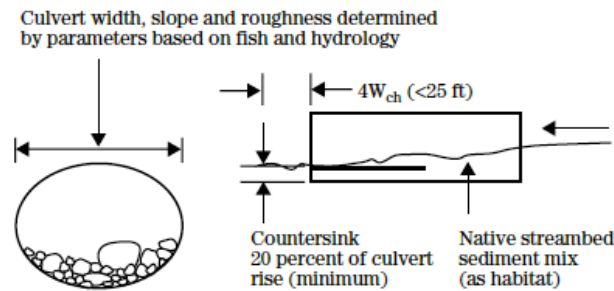

Figure 26. Hydraulic design option culvert schematic

A general design sequence for developing a hydraulic design culvert is:

- Step 1* Determine culvert length based on road fill geometry.
- Step 2* Determine target species, sizes, migration timing, and swimming capabilities to calculate maximum barrel velocities and lengths.
- Step 3* Determine design flows at which criteria from step 2 must be satisfied. For example, WDFW (2003) suggests using the 10-percent exceedance flow for adult salmonids of a target species as the high design flow. For adult passage at low flows, NOAA Fisheries Service (2000) recommends using the 50 percent annual exceedance flow or 3 cubic feet per second (whichever is greater), and for juveniles, the 95 percent annual exceedance flow or 1 cubic foot per second (whichever is greater).
- Step 4* Select culvert size, shape, roughness, and slope that satisfy barrel velocity criteria.
- Step 5* Calculate or model hydraulics within the selected culvert to ensure that flow is subcritical throughout design flow range for fish passage.
- Step 6* Determine channel backwater elevation at culvert outlet throughout design flow range for fish passage.
- Step 7* Set culvert elevation so that low and high design flows for channel backwater are at least as high as the water surface in the culvert.
- Step 8* Verify that selected culvert will provide adequate flood-flow capacity.
- Step 9* If necessary, adjust channel profile to match needed culvert elevation.

The hydraulic design process might include iterations between steps 4 and 9 to arrive at the final design option that simultaneously considers the hydraulic effects of culvert size, slope, and configuration against the physiological requirements of migratory fish. A hydraulic design

culvert should be countersunk at least 20 percent at the outlet and set at a shallow grade (<1%). Although stream substrates can settle out inside the culvert barrel, they are often removed by subsequent high flows. Finally, low-flow hydraulics within culvert corrugations should be considered where passage is essential for small-bodied or weak swimming fish.

Some useful hydraulic design analysis tools and reference literature are available on the Internet. FishXing (fish crossing) is a system of software and learning resources specifically aimed at the issue of fish passage within culverts. This software (including documentation) downloads an annotated bibliography of fish passage through culverts, and additional topical resources can be accessed at:

<http://www.stream.fs.fed.us/fishxing/>

Tide gates and floodgates

Tide gates and floodgates are usually a pipe or culvert outfitted with a gate (flap) on the outlet end that allows water to flow in only one direction. They are usually incorporated into earthen dikes and, in many cases, include pump stations. Floodgates operate in nontidal areas to prevent floodwaters from backing up into smaller tributary streams or drainage ditches. Tide gates are designed to keep saltwater out of agricultural fields, drainage ditches, and freshwater streams that flow into estuary and coastal areas. For both structures, as long as positive head remains on the upstream side, the flap remains open and allows water to drain. When the receiving water body rises (for a floodgate), or when the tide comes in (for a tide gate), the outlet flap shuts and prevents saltwater or floodwater from entering the culvert. Pumps may be necessary to move water over the dike.

Flaps (gates) can be actuated manually, mechanically, electrically, or (for most flaps) by the difference in head pressure across the culvert or pipe. Flaps can be any shape and are usually hinged to either the top or the side of the culvert outlet. Older gates are usually composed of heavy steel that do not open very wide or remain open for extended periods. These factors significantly diminish passage conditions for migratory fish. In recent years, fish passage has been improved by replacing heavy steel flaps with lightweight aluminum or plastic flaps (fig. 27). Aluminum and plastic tide and floodgates are attractive to landowners because they open under much lower head differentials, pass debris easier, and have greater conveyance capacity.

(a) Two 1,800-lb steel tide gate flaps created a partial passage barrier for several fish species and age groups.

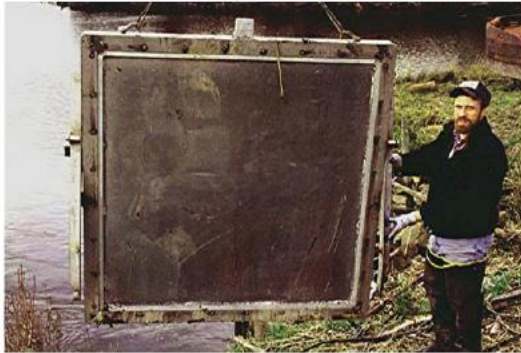

(b) Two 100-lb aluminum replacement flaps provide more efficient fish passage.



Figure 27. Improved fish passage

Most dikes associated with floodgates and tide gates are constructed high enough to hold back drainage until stage in the receiving water begins to drop and the flap once again opens. In coastal and estuarine settings, dike height depends on tidal elevation where the dike crosses over at the tide gate—the higher the tidal elevation, the lower the dike. Generally, a flap opens and drains the freshwater twice in a 24-hour period. For both tide gates and floodgates, suspended sediment, floating debris, and bed load tend to settle to the bottom of the channel when the upstream drainage is backwatered by a closed flap. When the flap opens again, some, but not all, of this material is carried through the culvert and downstream. Consequently, all of these channels require periodic dredging and some form of debris removal.

Generally, a channel reach affected by periodic tide gate or floodgate closures provides marginal fish habitat. Woody riparian vegetation is difficult to establish and maintain along these channel reaches because of frequent inundation by salt and freshwater. In addition, adjacent landowners discourage brush and tree growth that could plug the gates with woody debris. A branch that becomes wedged in the flap can allow saltwater to move far up the freshwater channel, damaging crops and affecting municipal and livestock water supplies. If a floodgate fails, acres of farmland, as well as flood plain infrastructure, can be damaged. However, the negative impacts to fish and wildlife may be minimal.

Estuarine tide gates can cause long-term negative impacts to fish and wildlife, not when they fail, but while they are functioning as designed. Estuaries are by far the most biologically productive ecosystem in the world and are defined as marine areas partly enclosed by land (a bay) that receive freshwater runoff from uplands. When this outlet is restricted, freshwater mixes with trapped saltwater and creates an area intermediate between freshwater and saltwater (brackish). Estuaries are critically important nurseries for juvenile marine fish, as well as numerous invertebrates such as crabs, lobsters, clams, and oysters. The yearly death and

regeneration of marine plants, coupled with a constant flushing of detritus and other materials from incoming streams, forms the basis of this estuarine food web. In addition to the rich production of marine plants and animals, an entire community of terrestrial predators and herbivores, including waterfowl, shorebirds, raptors, furbearers, and marine mammals, creates a productive, diverse ecosystem.

Tide gates can be partial or complete barriers to migratory fish passage. However, their greatest negative impacts are related to the severe ecological changes they cause to the estuary. Tide gates and their associated dikes are often set well below the high-tide line. Consequently, they create a distinct demarcation between freshwater uplands and saltwater intertidal habitat, destroying the gradual change between freshwater and marine habitats. Plants and invertebrates found only in estuarine environments disappear and salt marshes are replaced with well-drained uplands that are usually managed for agricultural crops or pasture. Salt marshes on the outside of the dikes become mud flats. Shallow beaches, formed and maintained by the highest tides and conditioned by long exposures to air and freshwater precipitation, become uplands. Further, tide gates allow mixing of freshwater and saltwater only twice per day, rather than 24 hours per day.

Juvenile marine fish, including young anadromous and catadromous fish, historically moved in and out of shallow estuary areas with the tides and were rewarded with a continuous food supply. Tide gates and saltwater dikes generally restrict these small fish to predominantly mud flats areas with less food diversity. Juvenile salmonids that are still adjusting to marine conditions cannot move between fresh and saltwater. Geomorphic and hydrologic changes in estuarine ecosystems attributable to dikes and tide gates force small fish to live in less suitable, deeper waters where longer exposures to predators can significantly increase mortality.

However, some landowners are allowing older, passive tide gates to be replaced with new self-regulating tide gates (SRT). These SRTs have various designs, but primarily function to allow not only better fish passage, but also more interchange of marine and freshwater. An SRT is equipped with a flotation device that causes the gate to open wider, more quickly, and remain open longer than conventional aluminum flap gates (fig. 28). Consequently, SRTs provide significantly improved fish passage conditions over older systems. Self-regulating tide gates also provide a range of improvements to land managers because they can be adjusted to shut completely at a preset tidal elevation to limit saltwater intrusion, or set to remain open throughout a given tidal change.



Figure 28. Self-regulating tide gate

1. Fishway operation and maintenance

Passage facilities must be operated and maintained properly for optimum success. Although operation and maintenance (O&M) activities vary according to the frequency with which personnel must physically visit a given facility, certain O&M elements are essential to keep a passage structure working properly. A critical O&M element is to post structural operating criteria at the facility site so that O&M personnel or the facility operator can properly adjust any controls to provide optimum passage conditions. Other essential O&M considerations include:

- specifying what entity is responsible for the daily operation and maintenance of a passage structure
- checking a passage structure at regular intervals to ensure it is operating within design criteria
- cleaning trashracks and debris collectors regularly
- adjusting gates, orifices, valves, or other control devices as needed to regulate flow and maintain a passage structure within operating criteria
- periodically checking staff gages or other flow-metering devices for accuracy
- annually inspecting passage structures for structural integrity and disrepair
- inspecting gate and valve seals for damage
- replacing worn or broken stoplogs, baffles, fins, or other structural components
- removing excessive sediment accumulations from within passage structure periodically

One of the most critical considerations regarding fishways, O&M is to ensure that excessive debris and sediment accumulations are removed as soon as possible. Sediment aggregations or debris caught in any part of the passage facility usually affects structural hydraulics and diminishes fish passage success.

2. Fish screen design

Fish screens preclude adult and juvenile fish from entering flow diversion structures, pump intakes, diversion channels, pipes, or penstocks. Although most screening facilities are designed to exclude juvenile fish from entrainment into diversions, pumps, or penstocks, adult screens can be constructed for the same reasons or to discourage false attraction into dead-end watercourses. Fish screens are often located at the inlet of a gravity diversion or attached directly to pump intakes. Most gravity diversion screens are configured with a bypass system to direct fish back to their stream of origin, especially if the screening structure is any distance down a diversion canal or ditch (fig. 29).

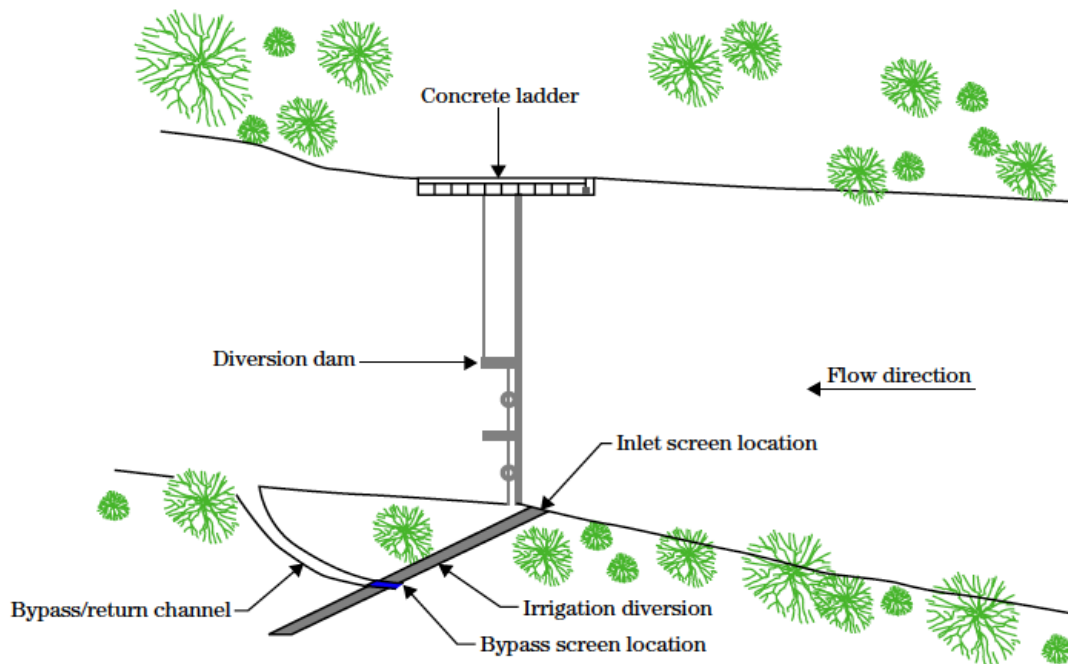

Figure 29. Potential fish screen configuration and locations

Fish screen biological design criteria

Fish screens are designed to limit mortality and injury to fish, while precluding entry into a water diversion structure or pump intake. Considerations required when designing a fish screen include (adapted from Nordlund 1997):

- preventing physical contact with the screen
- eliminating impingement onto the screen
- eliminating entrainment through the screen mesh
- maximizing bypass design to conduct fish quickly back to their stream of origin
- minimizing predation in the screen forebay, bypass pipe, and outfall
- managing for debris accumulations in bypass pipes, head gates, or trash racks
- minimizing excessive delay of fish due to poor hydraulic guidance conditions

Biological design criteria and site considerations are necessary when identifying appropriate screen location, type, and design. Required criteria include the swimming and leaping capabilities of target species and any site-specific attractors and distractions that may affect screen function. Screen hydraulics that influences swimming capabilities of juvenile fish are sweeping and approach velocities, water temperatures, body size, swim durations, and dissolved oxygen levels. Behavioral characteristics that affect juvenile migration can vary considerably and may include desire to move downstream and reluctance to enter small bypasses. These considerations and criteria should guide biologists and designers throughout the screen design process. Once biological design criteria are identified, a designer should evaluate several hydraulic characteristics of the diversion to evaluate the potential for fish entrainment or attraction.

Certain aspects of fish screen design criteria are now well understood for some species (such as maximum approach velocity, sweeping velocities, and minimum mesh opening), but data for many species are lacking. Further, years of operation and research on general screen types has produced a set of useful design guidelines. For example, NOAA Fisheries Service (1995) has developed fish screening criteria for salmonids and suggests the following criteria for protecting juveniles:

- Approach velocity should be no more than 0.40 feet per second for active screens and 0.20 feet per second for passive screens. Active screens are juvenile fish screens equipped with automatic cleaning systems. Passive screens have no cleaning mechanisms. Approach velocity is flow diversion rate divided by effective screen area, where effective screen area is equal to maximum flow diversion divided by allowable approach velocity.
- For rotating drum screens, submergence should not exceed 85 percent nor be less than 65 percent of the screen diameter. Submergence greater than 85 percent significantly

increases the possibility fish will be entrained over the screen and the chance fish will be impinged without entrainment. Submerging rotating screens less than 65 percent reduces self-cleaning capabilities.

- Screens longer than 6 feet should be angled, with sweeping velocity greater than approach velocity. Optimal sweeping velocities are between 0.8 and 3 feet per second.
- All screens should be designed to provide uniform flow across the screen surface.

Fish screen types

Several types of fish screens are available to the designer. Each function under different flow conditions and diversion configurations and require varying operation and maintenance requirements. The following sections describe most of the typical fish screens in use today (Nordlund 1997).

Vertical fixed plate screen—The vertical fixed plate screen is a perforated metal plate acting as a physical barrier with no moving or mechanical parts. It can be used for domestic industrial water supply and agricultural irrigation diversions and can be placed along the bank of a river, thereby eliminating the need for a bypass channel. This screen type requires manual cleaning and debris removal, and many designs incorporate an accessible trash rack in front of the screen (WDFW 2000b). Design of the structure should include practical considerations for debris removal and cleaning operations (fig. 30 (WDFW 2000b)). In addition to the standard vertical alignment, these screens can be angled upstream, downstream, inclined, or declined as needed to fit site geometry and design hydraulics.

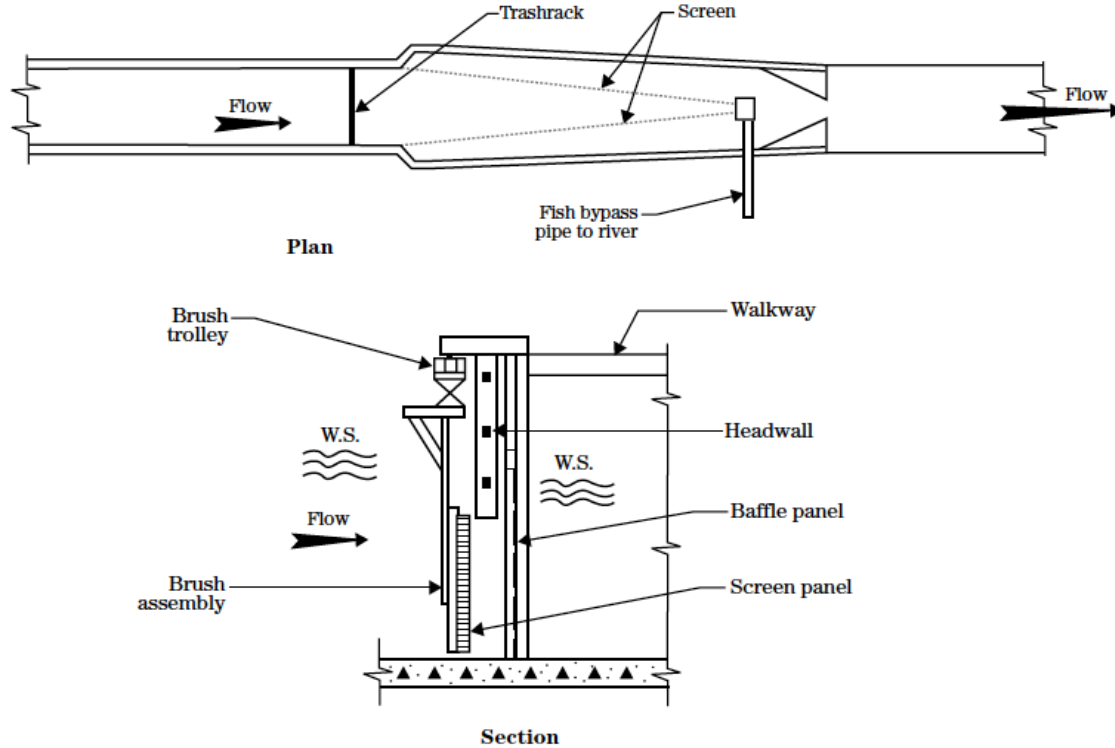

Figure 30. Vertical fixed plate screen

Vertical traveling screen—A vertical traveling screen is similar to the vertical fixed plate screen, except that the screen media rotates on a conveyor that automatically cleans the structure by moving debris downstream into a ditch or canal (fig. 31 (WDFW 2000b)). Vertical traveling screens are commonly used for pump intakes and can be installed in deep water. These screens require a power source (electric hookup, solar panels, paddlewheel) to rotate the screen and function properly. Vertical traveling screens can reduce the amount of manual maintenance and screen cleaning required at a facility, but these screens are more difficult to install and properly seal than fixed screen designs. Originally, panel or belt-type traveling screens were designed for debris management at pump stations. Although outfitting traveling panels with adequate screen media will protect fish from entrainment, designers should provide detailed design specifications wherever these screens are planned for installation and operation (WDFW 2000b).

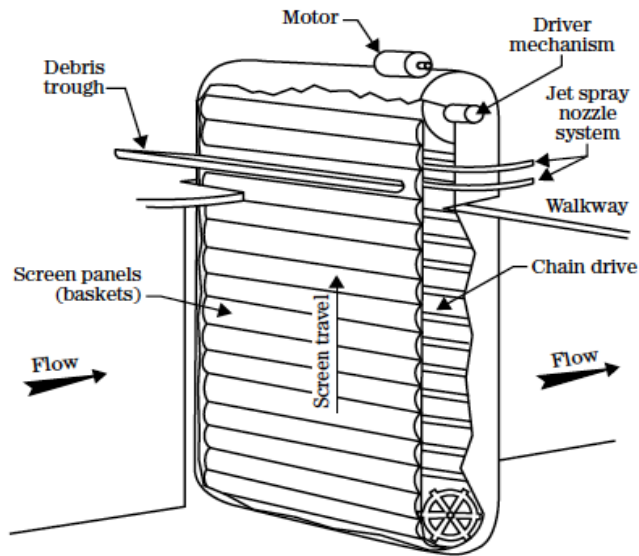

Figure 31. Vertical traveling screen

Rotary drum screens—Rotary drum screens are very effective in screening juvenile fish and are perhaps the most common screening technology in use across the Pacific Northwest (fig. 32 (WDFW 2000b)). Rotary screens are usually installed at gravity diversions and have been applied singularly or in multiples in canals sized for diversion rates from a few to thousands of cubic feet per second. These screens are comprised of a rotating cylinder with a mesh surface. As the cylinder rotates, it carries debris over the screen where it washes or falls off the backside of the screen into a diversion canal or ditch.

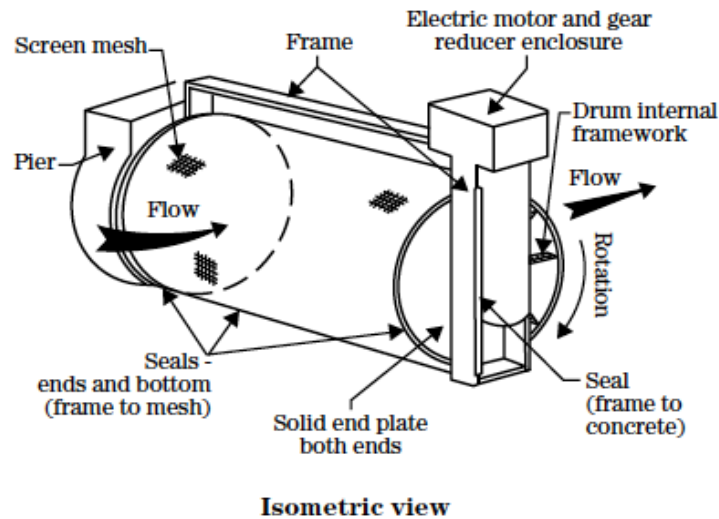
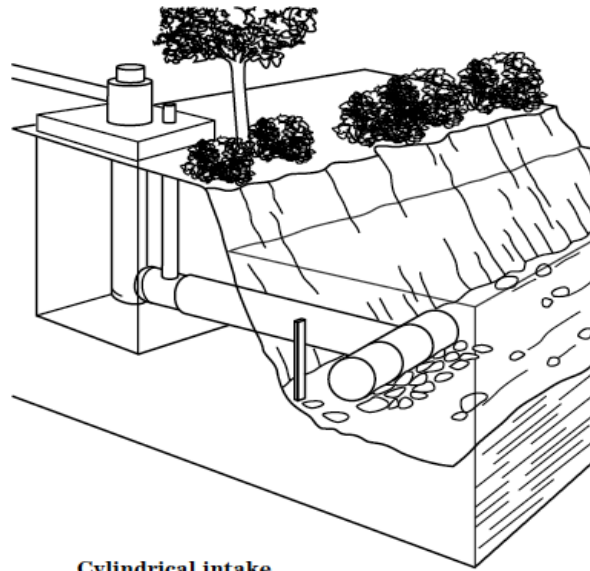

Figure 32. Rotary drum screen

Rotary screens generally have less cleaning and maintenance requirements than a fixed or moving vertical plate screen, but side and bottom seals must be regularly inspected and replaced to ensure a fish tight facility. Each rotary drum is driven by a motor or mechanized propulsion system (commonly, a paddle wheel, turned by the flowing water), so an adjacent power supply is necessary. Drum seals, drive motors, bearings, and gears often wear out, so long-term maintenance and equipment costs can be a factor. Rotary drum screens only operate under a relatively narrow range of water surface fluctuations, so site hydraulics must be well defined prior to selecting this design option (WDFW 2000b).

Pump intake screens—Pump intake screens are designed to protect fish from being sucked into the end of an intake pipe. Pump screens are generally designed as box or cylindrical chamber composed of wire mesh (fig. 33). These screens are usually fully submerged and are cleaned with an air jet or hydraulic flushing system. Pump screens are used in a wide range of applications from small irrigation pump diversions to large scale domestic and industrial water supply intakes. A primary disadvantage of pump screen installations is that the system is completely submerged (making it harder to inspect or repair), backflush systems may not always operate as intended, and expensive cleaning and maintenance routines may be required.



Cylindrical intake

Figure 33. Pump intake screens

Numerous manufacturers offer off-the-shelf pump intake screens for applications where intakes are sized for 5 cubic feet per second or less. As with other screening facilities, pump screens should be designed to minimize the potential for fish impingement and injury on screen media while pumps are operating.

Infiltration galleries—Infiltration galleries can be used as a natural approach to pump or diversion intake design. Water infiltrates riverbed substrate, which acts as the fish screen, into a system of perforated pipe (fig. 34 (WDFW 2000b)). Infiltration galleries can be used for both pump and gravity diversions and have been installed for domestic, industrial, and agricultural water supplies. The key to installing an infiltration gallery is properly locating the system at a stable river section with no deposition of fines and sands to clog the filter fabric around the infiltration pipes. Typically, these locations are along higher gradient riffles or in deep pools that scour frequently. In general, infiltration galleries have higher failure risks because of clogging from debris and sediment. Further, clogged systems can incur high maintenance costs and require invasive instream construction methods to uncover system components buried beneath river substrates.

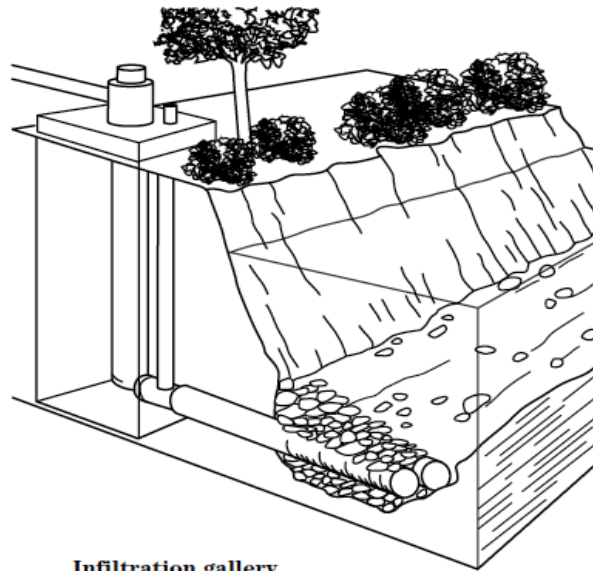

Infiltration gallery

Figure 34. Infiltration gallery

Several additional screen types are available to the designer and include modified horizontal plate and inclined plane configurations. The reader is encouraged to consult WDFW (2000b) at the following Web site for additional details and design criteria:

<http://wdfw.wa.gov/hab/ahg/screen51.pdf>

3. Screen design approach

When designing a screen, the primary objectives are to meet diversion requirements; minimize trapping, injury and harm to fish; and minimize cost, maintenance and repair. The size of the screen is ultimately a function of diversion requirements, screen opening size, and fish swimming capabilities. The following section describes a simplistic approach for screen design.

Screen mesh sizing

Screen mesh size is the opening in the screen face material (fig. 35). Screen openings can be round, square, rectangular, or any combination thereof. A variety of screen mesh materials are available to the designer and regional or local criteria may be developed for target species. The designer should consult local fish and wildlife agency for more information. Screen media should be smaller than the smallest life stage of the smallest target species present at the project site. An example of screen mesh size requirements based on testing results for screen

openings for fry-sized salmonids adopted by NOAA Fisheries is presented in table 9. These openings represent the minimum screen opening dimension in the narrowest direction (Nordlund 1997; WDFW 2000b).

A primary screen parameter in evaluating screen design is the relationship between screen mesh size (A_{opening}) and the overall area of the screen (A_{screen}). For the purposes of this handbook, the ratio between the screen mesh size and the overall screen area is called the screen size ratio (eq. TS14N-28 (WDFW 2000b)). Screen size ratio varies depending on the type of screen materials specified for the project and target species.

$$A\% = \frac{A_{\text{openings}}}{A_{\text{screen}}} \quad (\text{TS14N-28})$$

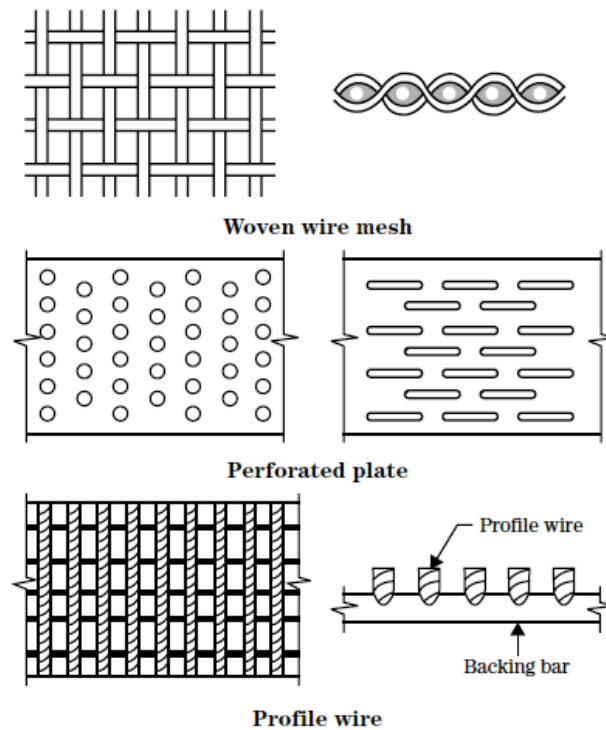

Figure 35. Fish screen wire and mesh configurations

Fish screen sizing (length and height)

The next step in designing the screen is determining the overall size (area) needed for the screen. The overall size is a function of the necessary flow diversion rate, screen size ratio, approach and sweeping velocities, and head losses through the screen. The general size of the screen is determined using the following steps.

Step 1 Determining velocities

Approach velocity is the velocity perpendicular to the screen that can impinge fish upon the screen and injure or kill the fish. Sweep velocity is the velocity parallel to the screen that sweeps fish off the face of the screen and directs them into the bypass structure. Approach and sweeping velocities are dependent upon diversion flow rate and the angle of fish screen alignment (fig. 36 (WDFW 2000b)). The sweeping velocity should always exceed the approach velocity so that fish are swept off the face of the screen. For lateral diversions on the riverbank, the approach velocity is negligible, whereas screens in bypass channels must be placed at an angle along the channel to ensure that sweeping velocity is larger than approach velocity (eqs. TS14N-29 through TS14N-31). In short, screens must be designed for orientations that ensure sweep velocity is larger than approach velocity.

$$1 < \frac{V_{\text{sweep}}}{V_{\text{approach}}} \quad (\text{eq. TS14N-29})$$

$$V_{\text{sweep}} = V \cos \theta \quad (\text{eq. TS14N-30})$$

$$V_{\text{approach}} = V \sin \theta \quad (\text{eq. TS14N-31})$$

where:

V = channel velocity (ft/s)

V_{sweep} = lateral velocity along the face of the screen (ft/s)

V_{approach} = velocity along the approach angle, perpendicular velocity normal to the face of the screen (ft/s)

θ = angle between the direction of channel flow and the screen (approach velocity and the sweep velocity)

| | |
|-------------------------|--------------------------------|
| Woven wire screen | 3/32 in = 0.09375 in = 2.38 mm |
| Perforated plate screen | 3/32 in = 0.09375 in = 2.38 mm |
| Profile bar screen | 0.0689 in = 1.75 mm |

Table 9. Examples of screen materials for fry-sized salmonids <60mm (minimum 27% open area)

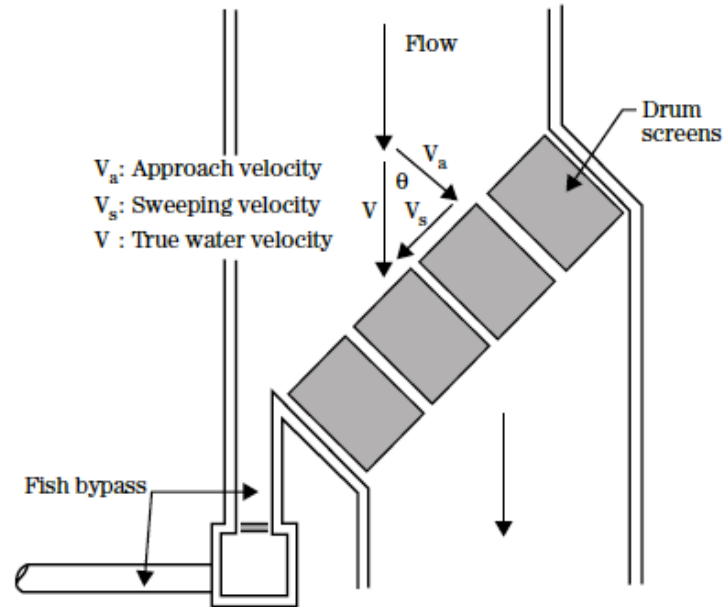

Figure 36. Sweeping and approach velocities

Step 2 Screen dimensions

The next step is to determine the area of screen opening to meet diversion requirements. This is an iterative process, whereby the designer estimates the area of the screen that will provide adequate flow into the diversion. Head losses are calculated and the area estimate is revised until the flow-diversion rate criteria are met. Final screen height and length are determined at the end of an iterative process to calculate flow diversion and required screen opening (eqs. TS14N-32 through TS14N-34).

The equation for flow through an orifice is the iterative design analysis.

$$Q = C A_{\text{screen}} (2g\Delta h)^{0.5} \quad (\text{eq. TS14N-32})$$

Head loss (Δh) can be estimated using the following equation.

$$\Delta h = \frac{1}{2g} \left(\frac{Q}{CA_{\text{screen}}} \right)^2 \quad (\text{eq. TS14N-33})$$

where:

- Q = diversion discharge (ft³/s)
 g = gravitational acceleration (ft/s²)
 C = loss coefficient for fine-meshed screens
 (0.6 for fine-meshed screens (Colorado School of Mines 2004))
 A_{screen} = estimated screen area to meet diversion requirements

$$A_{\text{screen}} = xyA_{\%} \quad (\text{eq. TS14N-34})$$

where:

- x = length of screen required to meet diversion requirements (ft)
 y = height of screen, plus head losses, required to meet diversion requirements (ft)

Bypass design

A fish bypass system is a flow route to transport both juvenile and adult fish from the face of a screen back to a river. Fish screens placed directly in or on the banks of a river require no bypass system. Bypass routes should transport fish back into a river or stream as quickly as possible, without injury or increased chance of mortality from predation. Major components of a fish bypass system include the entrance, transport conduit, and outfall or exit. Major design considerations for each of these components are summarized.

Bypass entrance

- Orient bypass entrances at the downstream terminus of a screen face.
- Include additional entrances if sweeping velocities will not move fish to one within 60 seconds of encountering the screen face.
- Entrance flow into the bypass system should always be 10 percent greater than the true water velocity approaching it. In screen sites with complicated or uncertain hydraulics, design bypass entrance flow to be 25 percent greater than approaching true water velocity.
- Bypass entrances should extend from the floor to the canal water surface and be a minimum of 18 inches wide (for diversions greater than 3 ft³/s) or 12 inches wide (for diversions less than 3 ft³/s). These widths allow schooling fish to move through without delay.

Bypass conduit

- All surfaces and joints should be smooth to reduce the risk of injury to fish.
- Maximum velocity should not exceed 30 feet per second with no hydraulic jumps. Optimum pipe velocity is around 6 to 12 feet per second.
- Flow inside the conduit should never be pressurized.
- Avoid extreme bends, and ensure that the ratio of bypass pipe centerline radius of curvature to pipe diameter (R/D) is greater than or equal to 5. Greater R/D may be required for supercritical pipe velocities.
- Size bypass conduit to minimize debris blockage, sediment deposition, and facilitate cleaning. Pipe diameter should be 24 inches or greater, but never less than 10 inches. Equip pipes longer than 150 feet with access valves.
- Never include closure valves inside a bypass pipe.
- Minimum depth of free surface flow should be at least 40 percent of bypass pipe diameter.

Bypass outfall

- Locate bypass exit where ambient river velocity is greater than 4 feet per second.
- Select an outfall location free of eddies and reverse flow to minimize predation. Require predator control systems where necessary.
- Ensure that outfall configuration will not direct fish into the river bottom.
- Design the exit so that the impact velocity of the outfall nappe or jet will not exceed 25 feet per second.

1. Maintenance and operation

Fish screens require periodic maintenance and cleaning to keep the diversion operational and the screen functioning properly. Trash racks, mechanical sweeper arms, manual cleaning, hydraulic flow jets and airburst features, backwash systems, and paddle wheels are used to keep the screen debris free. The designer should include either a mechanical debris removal feature or maintenance personnel for clearing the fish screen as part of a long-term operation and maintenance plan.

2. Example problem: Preliminary design for fish passage

An irrigation district has been informed by a local fish and wildlife agency that a 10-foot-high concrete diversion dam is a fish passage barrier. The recommendation to the district is to modify the structure to provide passage for Upper Columbia steelhead that migrate and spawn between January and May each year. The preferred plan is to use a historical overflow channel

to construct a permanent, stable, natural-type stepool rock ladder around the diversion to provide fish passage. The plan is to construct a series of 10 boulder weirs along the fish passage channel which is approximately 200 feet long (20 ft spacing). The channel will be slightly wider than the weir length.

An analysis of hydrology and hydraulics of the river and diversion dam provided stage discharge relationship information and helped identify the Q_{hf} , Q_{avg} , and Q_{lf} design discharges for the fish passage channel. Fish passage will be provided for all design flow conditions. They are:

$$Q_{hf} = 100 \text{ ft}^3/\text{s}$$

$$Q_{avg} = 30 \text{ ft}^3/\text{s}$$

$$Q_{lf} = 15 \text{ ft}^3/\text{s}$$

The first step in sizing the weir features is to determine the general geometry. This is an iterative process. For the high-flow condition (Q_{hf}) the weir invert elevation is set such that there is 2 feet of head (H) on the fish passage diversion inlet (passage exit). Using equation TS14N-18, the length of the weir is back calculated.

$$Q = C_d \left(\sum_i^N (L_i - 0.1NH) \right) H^{1.5}$$

where:

L_i = incremental widths (ft)

N = number of contraction sides (2)

H = head on weir (2 ft)

C_d = coefficient of discharge = 3.1

English units

$$100 \text{ ft}^3/\text{s} = 3.1 \left(\frac{\sqrt{\text{ft}}}{\text{s}} \right) [(L - 0.1(2)(2 \text{ ft}))](2 \text{ ft})^{1.5}$$

$$L = 12 \text{ ft}$$

For the low-flow condition (Q_{lf}), the minimum amount of head (H) on the weirs is selected as 0.7 feet per guidance on depth requirements for steelhead. The configuration of the boulder weirs is similar to figure 13.

$$15 \text{ ft}^3/\text{s} = 3.1 \left(\frac{\sqrt{\text{ft}}}{\text{s}} \right) [(L - 0.1(4)(0.7 \text{ ft}))](0.7 \text{ ft})^{1.5}$$

$$L \approx 7 \text{ ft}$$

The total low-flow (Q_{lf}) weir length is on the order of 7 feet for two openings and four contraction walls.

The next step, using equation TS14N–3, is to check the weir velocity.

$$V_{weir} = \frac{Q}{L0.67H}$$

where:

V = velocity (ft/s)

L = weir length

$$V_{weir-hf} = \frac{100 \text{ ft}^3/\text{s}}{(12 \text{ ft})(0.67)(2 \text{ ft})} = 6.2 \text{ ft/s}$$

$$V_{weir-hf} = \frac{15 \text{ ft}^3/\text{s}}{(7 \text{ ft})(0.67)(.7 \text{ ft})} = 4.5 \text{ ft/s}$$

Velocities for the (Q_{hf}) and (Q_{lf}) are checked against the swimming abilities of steelhead and are well within range for the fish (table 10). The channel velocity is near the steelhead sustained swim speed, which indicates that there is room for design modification, if needed, including narrowing the flow channels and raising water surface and drop heights.

| Species | Sustained speed | | Cruising speed | | Burst speed | | Maximum jump height | |
|-----------|-----------------|------|----------------|------|-------------|------|---------------------|-----|
| | ft/s | m/s | ft/s | m/s | ft/s | m/s | ft | m |
| Steelhead | 4.6 | 1.40 | 13.7 | 4.18 | 26.5 | 8.08 | 11.2 | 3.4 |

Table 10. Steelhead swimming design criteria

The next step, using equation TS14N–19, is to estimate the scour depth below the downstream bed at the toe of the rock weir. Note that the equation uses metric units.

$$Y_s = 6\Delta h^{0.25} q^{0.5} \left(\frac{Y_d}{D_{90}} \right)^{\frac{1}{3}}$$

where:

Y_s = depth of scour (m)

Y_d = downstream depth of flow (m) = 2 ft = 0.6 m

q = unit discharge ($m^3/m-s = 100 \text{ ft}^3/s/12 \text{ ft} = 8.3 \text{ ft}^2/s = 0.8 \text{ m}^2/s$)

D_{90} = sediment diameter with 90% of material finer
(mm = assumed 6-in material = 152.4 mm)

Δh = difference in head between upstream water surface and downstream water surface including velocity (m = 1 ft = 0.3 m)

$$Y_s = 6(0.3)^{0.25} (0.8)^{0.5} \left(\frac{0.6}{152.4} \right)^{\frac{1}{3}} = 0.6 \text{ m} = 2.0 \text{ ft}$$

The next step, using equations TS14N–20 and TS14N–21, is to check the assumed step length and drop to scour ratio to see if they are similar to those found in natural systems.

For slopes between $0.05 < \frac{h}{L} < 0.50$

$0.05 < \frac{1 \text{ ft}}{20 \text{ ft}} < 0.50$ Check, spacing could be moved closer together and shorten reach overall.

The drop to scour ratio is $1.0 < 1 + \frac{Y_s}{h} < 3.0$

$$1.0 < 1 + \frac{2.0 \text{ ft}}{1 \text{ ft}} < 3.0 \quad \text{Check.}$$

The final steps are sizing the rock material for the weir crest, scour hole toe protection, and downstream tailwater area.

The weir and scour velocity (V_1) is determined using equations TS14N–25 and TS14N–24.

$$V_y = \sqrt{2g\Delta h}$$

$$V_y = \sqrt{2(32.2 \text{ ft/s})(1 \text{ ft})} = 8.0 \text{ ft/s}$$

$$V_1 = \sqrt{V_{\text{weir}}^2 + V_y^2}$$

$$V_1 = \sqrt{(6.2 \text{ ft/s})^2 + (8.0 \text{ ft/s})^2} = 10.1 \text{ ft/s}$$

Evaluating table 10 and equation TS14N–23 indicates that the rock size on the weir should be approximately 1 to 2 feet in diameter. These values compare well with the general rule that the

rock size should be larger than the drop height of 1 foot. A selection of 2-foot-diameter material for weir and scour pool area protection is recommended. In addition, this size material should also be laid as a subsurface armor layer along the entire length of the furthest downstream step and tailwater area to provide a keystone grade control feature for the entire channel.

$$D_{50} = \left(\frac{V_1}{2.57} \right)^2$$

$$D_{50} = \left(\frac{10.1 \text{ ft/s}}{2.57} \right)^2 = 15.4 \text{ ft}$$

The final rock size estimate is for the bed material along the tailwater area using equation TS14N-3 in conjunction with a modified version of equation TS14N-23 and cross-checking with table 10. All approaches indicate that the tail out material should be composed of large cobbles greater than 5-inches in diameter. The following approach is appropriate if the downstream tailwater area has a flatbed slope; otherwise, the resultant velocity vector including the vertical direction must be used.

$$V_{\text{weir}} = \frac{100}{(12)(0.67)(2)} = 6.2 \text{ ft/s}$$

$$D_{50} = \left(\frac{6.2 \text{ ft/s}}{2.57} \right)^2 = 5.8 \text{ in} = 0.5 \text{ ft}$$